



CAUTION: CAREFULLY READ INSTRUCTIONS BEFORE PROCEEDING.

OVERVIEW

CD-1 marine capacitive discharge ignition system P/N 103003 is intended for V8 performance marine applications. The CD-1 marine system includes CD-1 marine ignition module P/N 103001 and coil P/N 103002.

- Compatible with 8 cylinder marine engines with distributor type ignition.
- 135 mJ spark energy output.
- Digitally set RPM limit with 100 RPM steps from 3,000 to 9,900 RPM.
- Seven switch selectable advance curves and a fixed timing mode cover most Mercury marine high performance applications.
- PC programmable idle stabilization feature.
- PC programmable advance features ranging from a simple RPM based advance curve to a 3D timing map with boost proportional retard.
- Built-in data logging capability with 16 Mbit DataFLASH memory stores up 5 hours of data at 10 samples/second or 30 minutes of data at 100 samples/sec.
- Dedicated input terminals for manifold pressure and an externally activated 0-18 degree retard feature.
- Three general purpose input/output terminals. Two inputs are reserved for data logging. An additional input/output terminal can be used for data logging or as an RPM window switch.
- Fully encapsulated construction. 12 pin Deutsch connector used for signal connections.
- Module and coil are both certified to meet the ignition protection requirements of the NMMA, the USCG, ISO 8846 and SAE J1171 standards for marine applications.
- Compact size. Module is 7.0"L x 5.25"W x 1.9"H. Coil is 4.4"L x 3.2"W x 3.0"H.

- Highly efficient switching power supply based on US Patents 6518733 and 6636021. Less than 5 amp current draw at 8,000 RPM.

ADDITIONAL REQUIRED PARTS

To use the PC link or data logging software, you will require the optional USB interface P/N 102004. To connect a Delphi MAP sensor, you will have to fabricate a wiring harness with the appropriate mating connector or use our MAP sensor harness kit P/N 102006. If your application will trigger the CD-1 direct from a Mercury Marine Hall effect distributor, you must use our P/N 103004 marine rotor or modify the existing rotor using the template in the Appendix.

The parts bag supplied with the CD-1 includes a signal harness that plugs into the 12 terminal Deutsch connector, ring tongue terminals for power and ignition coil connections, and a set of Weather Pack connectors for tach and PC link hookup. To complete the installation, some applications may require additional wire, crimp terminals, fuses, switches, and relays. The Appendix includes a list of recommended parts and suppliers.

Figure 1 – CD-1 Marine System



WIRING OVERVIEW

Power Connections		
Heavy (12 AWG) Red	Battery+	Connects to battery positive terminal. Do not connect to the alternator. If leads must be extended, add filter capacitor as shown in basic hookup diagrams.
Heavy (12 AWG) Black	Ground	Connects to chassis ground.
Ignition Coil Primary Connections		
Orange	Coil+	Connects to coil positive terminal
Black	Coil-	Connects to coil negative terminal
Deutsch Connector Signals		
Red (Pin 1)	Ignition Switch	Connects to ignition switch
Blue (Pin 2)	Retard Input	Connects to external switch to command retard
Orange (Pin 3)	GPI1	General purpose input 1. Used for data logging only
Gray (Pin 4)	GPIO2	General purpose input/output 2
Yellow (Pin 5)	GPIO3	General purpose input/output 3. Used for data logging only
Violet (Pin 6)	Magnetic Trigger+	Connects to magnetic pickup distributor or crank trigger. If the magnetic trigger inputs are used, the trigger input on pin 12 must be left open.
Green (Pin 7)	Magnetic Trigger-	Connects to magnetic pickup distributor or crank trigger. If the magnetic trigger inputs are used, the trigger input on pin 12 must be left open.
Pin 8	Sensor Ground	Connects to MAP sensor ground
Pin 9	MAP Sensor	Connects to 0-5V MAP sensor signal
Pin 10	+5V Power	Connects to MAP sensor power
Brown (Pin 11)	Tach/RS-232	Connects to tach and optional USB interface
White (Pin 12)	Hall Effect/Module Trigger	Connects to Mercury Marine Hall effect distributor or trigger output from engine control module. If this trigger input is used, the magnetic trigger inputs on pins 6 and 7 must be left open.

Figure 2 – Basic Magnetic Trigger Hookup

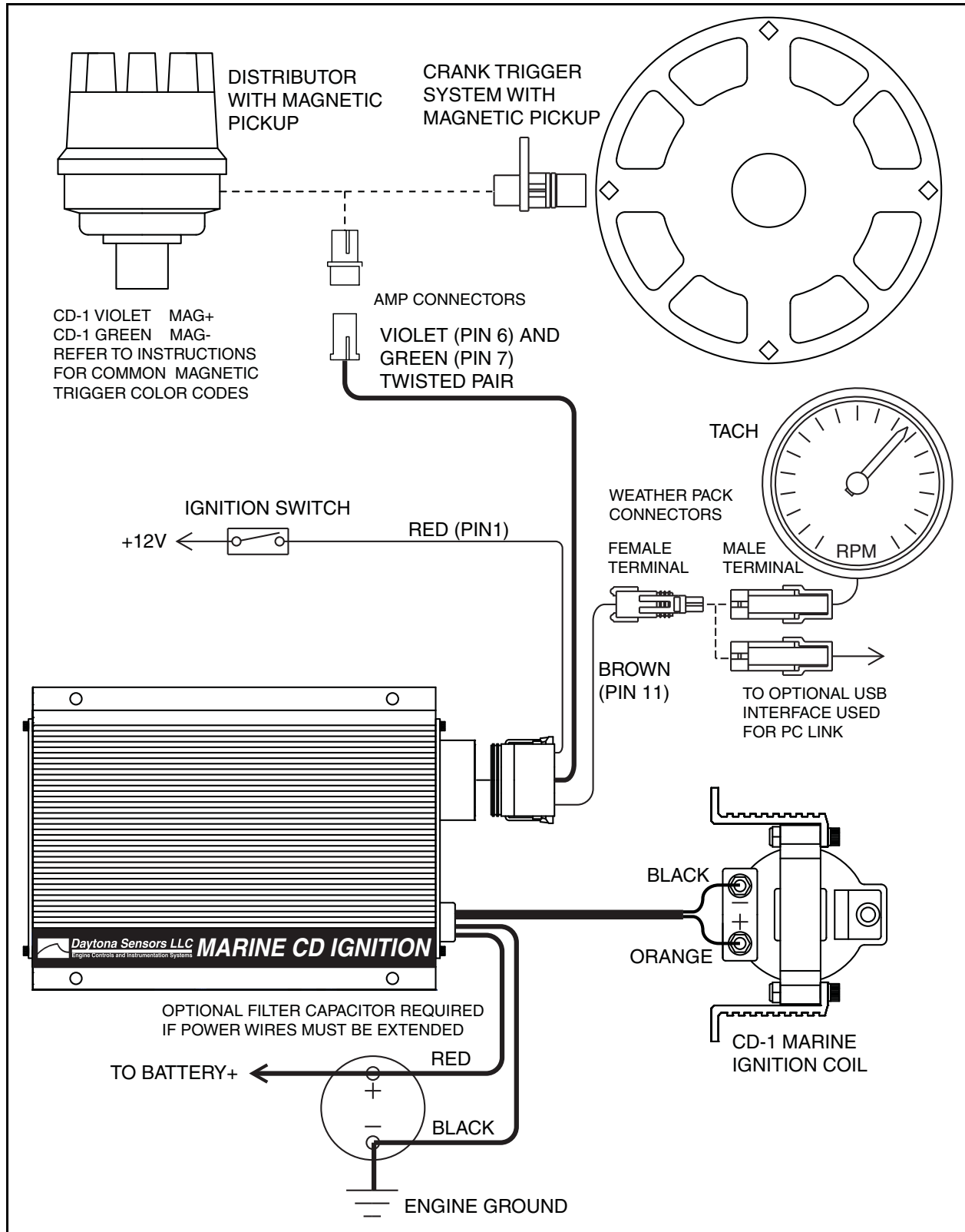

Figure 3 – Basic Mercury Marine Hall Effect Distributor Hookup

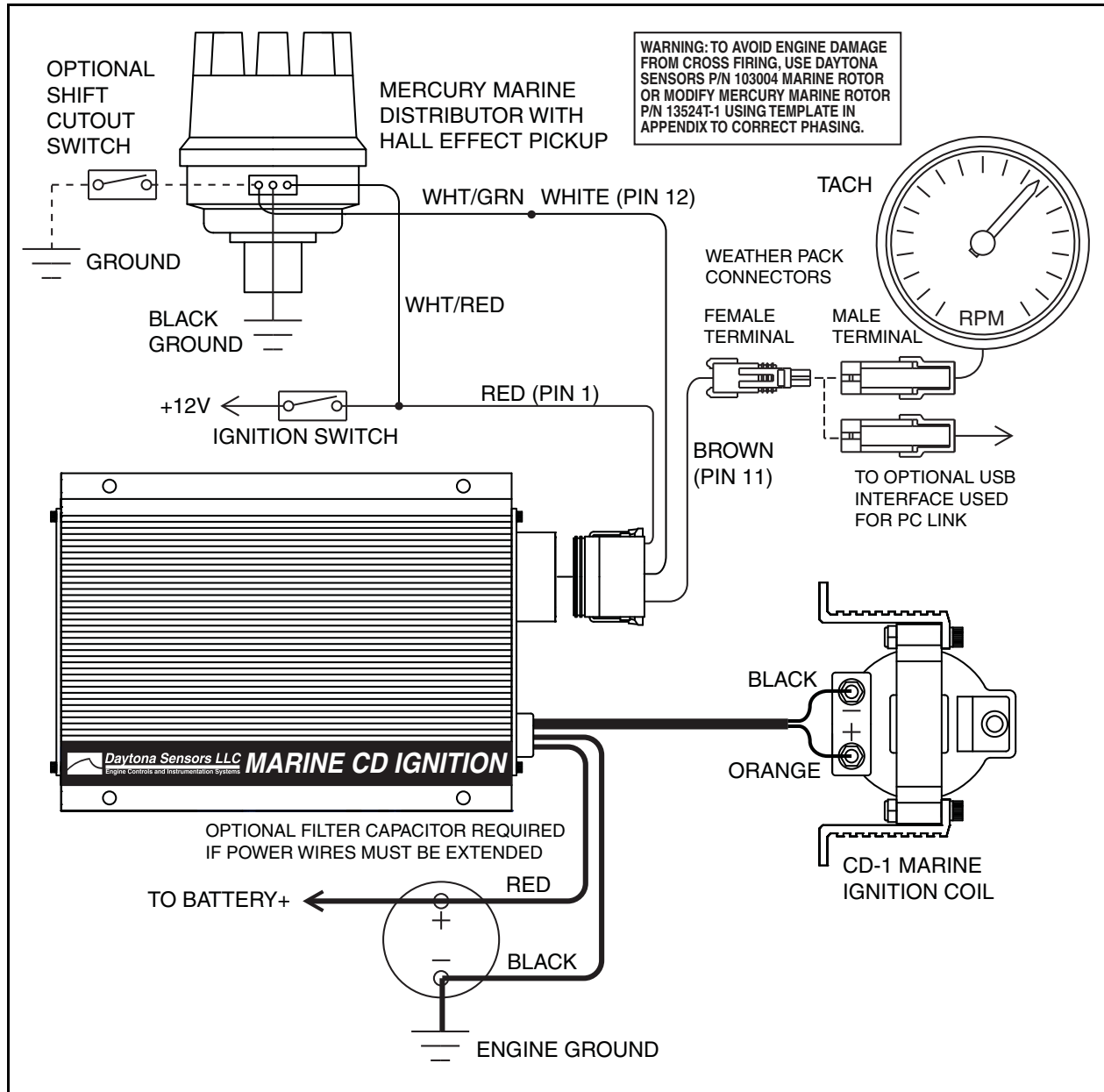
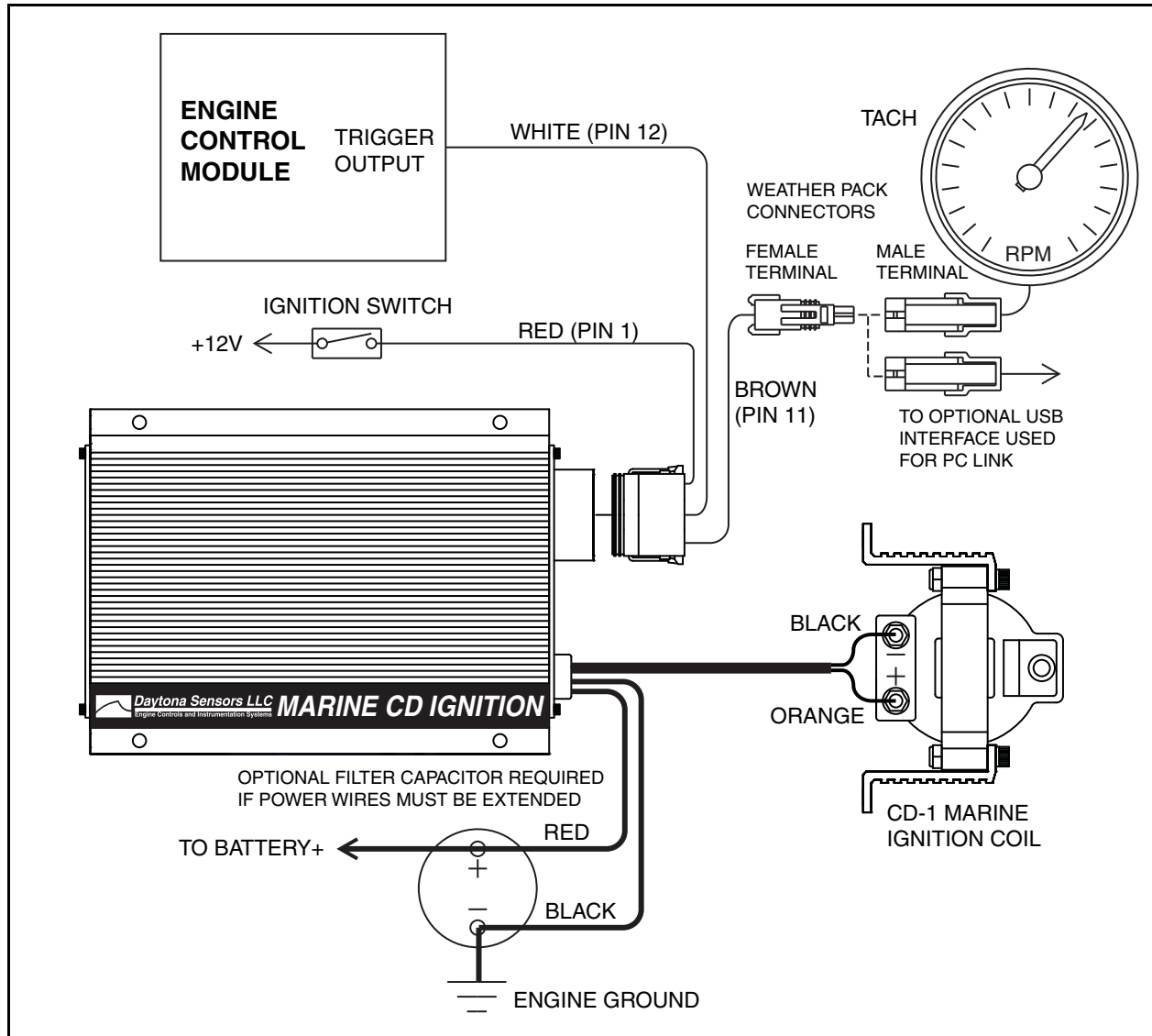

Figure 4 – Basic Module Trigger Hookup



INSTALLATION

1. Turn off the ignition and any battery disconnect switches before proceeding.
2. Select a convenient mounting location in the engine compartment for the CD-1 module and coil. Do not mount the module or coil directly on the engine. We recommend using rubber shock mounts such as McMaster-Carr (www.mcmaster.com) P/N 9376K72. Orient the unit so that you will have easy access to the rotary switches.
3. Refer to Figures 2-4 for basic hookup. For corrosion protection in marine environments, apply Permatex P/N 22058 dielectric grease to all electrical terminals (not required on the sealed Deutsch and Weather Pack connectors).

WARNING: Do not cut the power or coil wires shorter than 12 inches. Doing so makes the unit impossible to test and will void the warranty.

4. **Power connections.** Connect the 12 AWG red wire to the battery disconnect switch or the battery cable at the starter solenoid. If the battery is mounted outside the engine compartment or the CD-1 red power wire must be extended, a filter capacitor is required and minimum 12 AWG wire should be used for the connection. You can use a 10000 UF 25V electrolytic capacitor such as our P/N 102007 capacitor kit or Mouser (www.mouser.com) P/N 539-CGS103U025RC3 and bracket P/N 539-VR3A. Ground the 12 AWG black wire to the engine, preferably where the battery ground cable is attached. Do not extend the black ground wire.
5. **Ignition switch connection.** Connect the red wire from Deutsch connector pin 1 to the ignition switch as shown.
6. **Trigger signal connections.** The violet/green magnetic pickup cable is supplied with an AMP connector that will mate with common MSD magnetic pickup distributors and crank trigger systems. For other magnetic pickups, cut off the connector and refer to the color code table below. For Mercury Marine Hall effect distributors, remove the Mercury ignition module. Use our P/N 103004 marine rotor or modify the existing rotor using the template in the Appendix. For module triggered applications from engine control modules, the CD-1 requires a 0-12V square wave signal and fires on

the rising edge. The module trigger input on pin 12 is tolerant of high voltage pulses and has an internal 680 ohm pull-up resistor to +12V.

Magnetic Trigger Color Codes		
System	Mag-	Mag+
Accel/Chrysler Distributor	Black	Orange/White
Accel Crank Trigger	Black	White
Moroso Crank Trigger	White	Black
MSD Crank Trigger	Green/Black	Violet/Orange
MSD/Ford Distributor	Violet	Orange
GM Distributor	Green	White

7. **Coil connections.** Connect the black and orange coil wires to the ignition coil as shown.

DANGER: High voltage is present at the coil primary and secondary terminals whenever the ignition switch is on. Do not touch or connect any test equipment to the coil terminals.

8. **Tach connection.** Use the supplied Weather Pack connectors as shown to connect the brown wire from Deutsch connector pin 11 to the tach as shown. The tach output is also used for PC link communications before the engine is started by means of an optional USB interface P/N 102004. When the engine is running an industry standard 0-12V square wave signal appears on the tach output with one tach pulse per trigger event. The rising edge of tach pulse is synchronized with the trigger event.
9. **Application specific signal connections.** Refer to the following sections and Figures 5-9.
10. **Completing the installation.** Remove any unused wires from the Deutsch connector and install supplied terminal seals. Set the CD-1 switches and upload any required setup program. Start engine and check timing. If timing has changed significantly, MAG+ and MAG- may be reversed.

Figure 5 – MAP Sensor Hookup

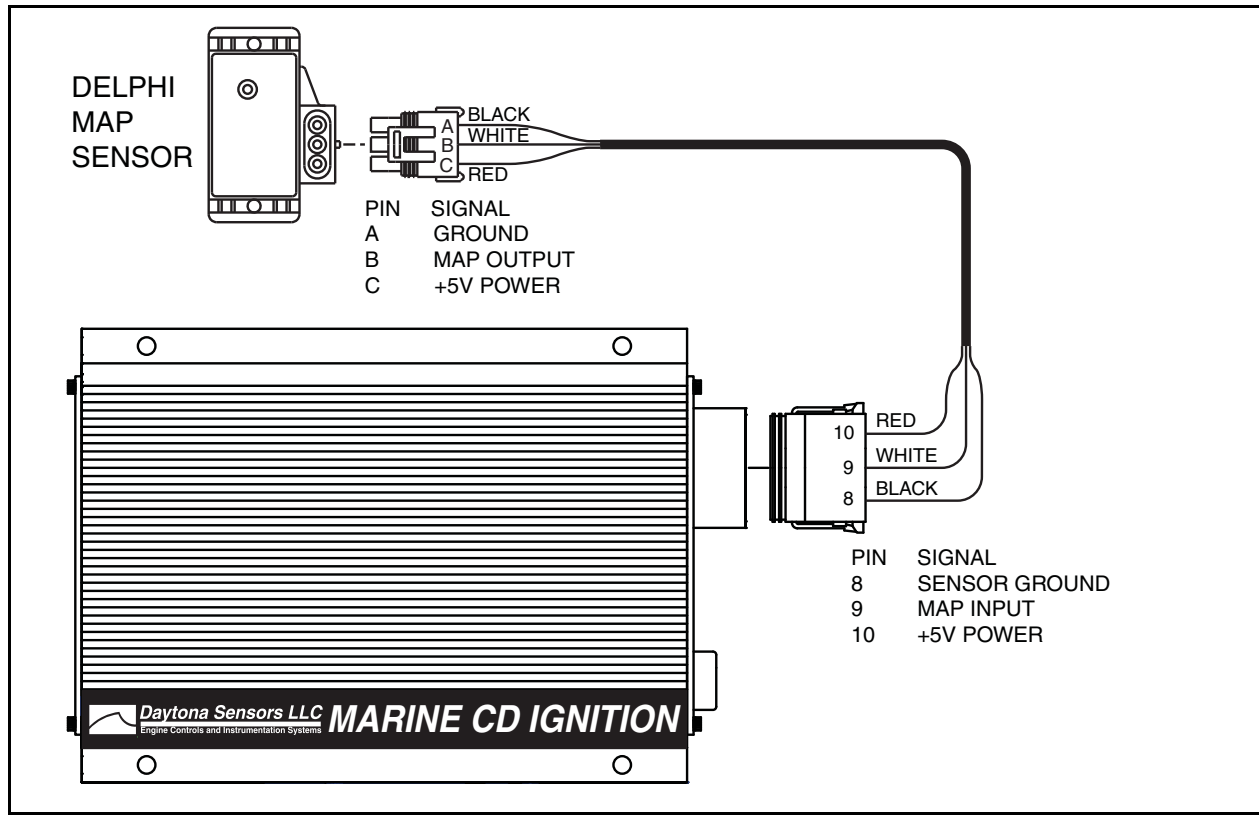

Figure 6 – Retard Input Hookup

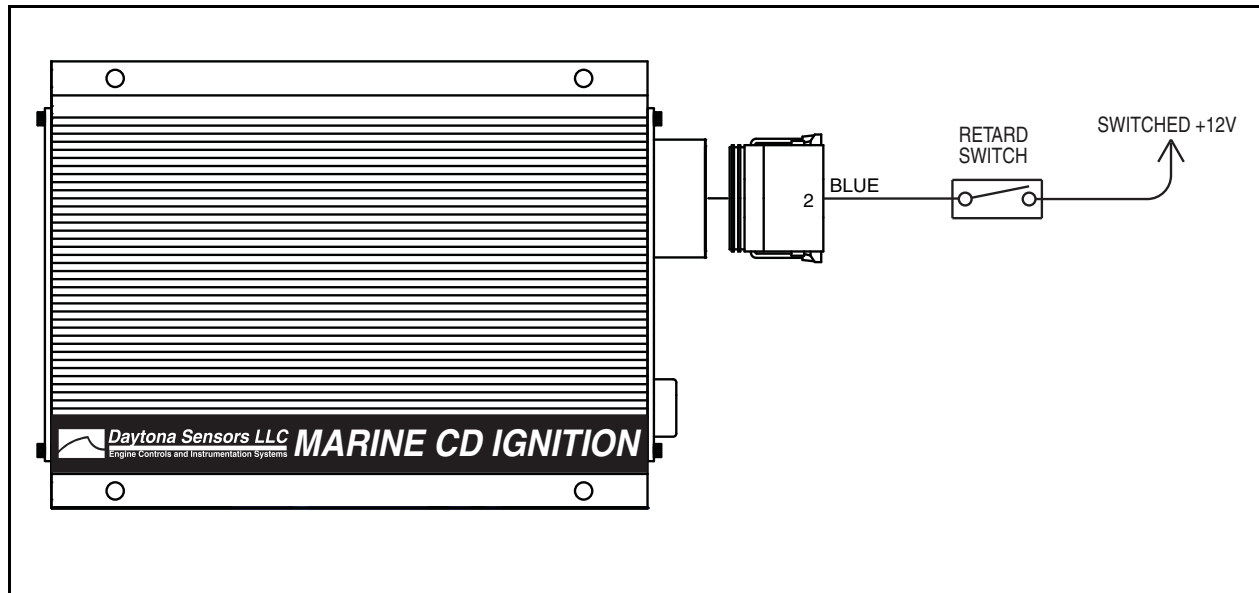

Figure 7 – GPI1 Data Logging Hookup Options

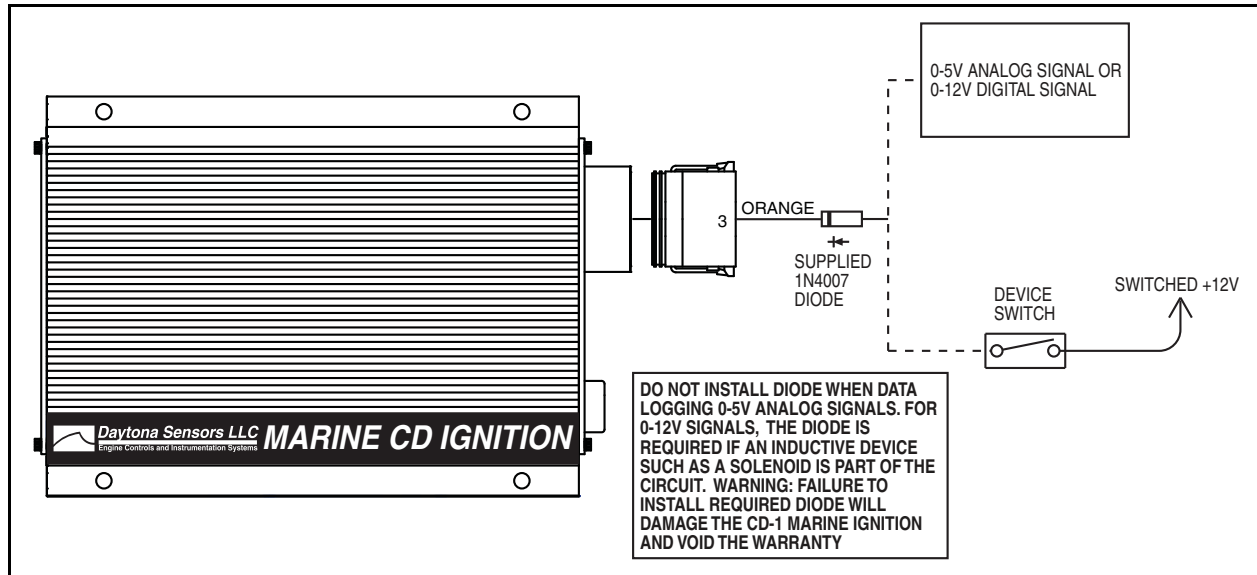

Figure 8 – GPIO2 Hookup Options

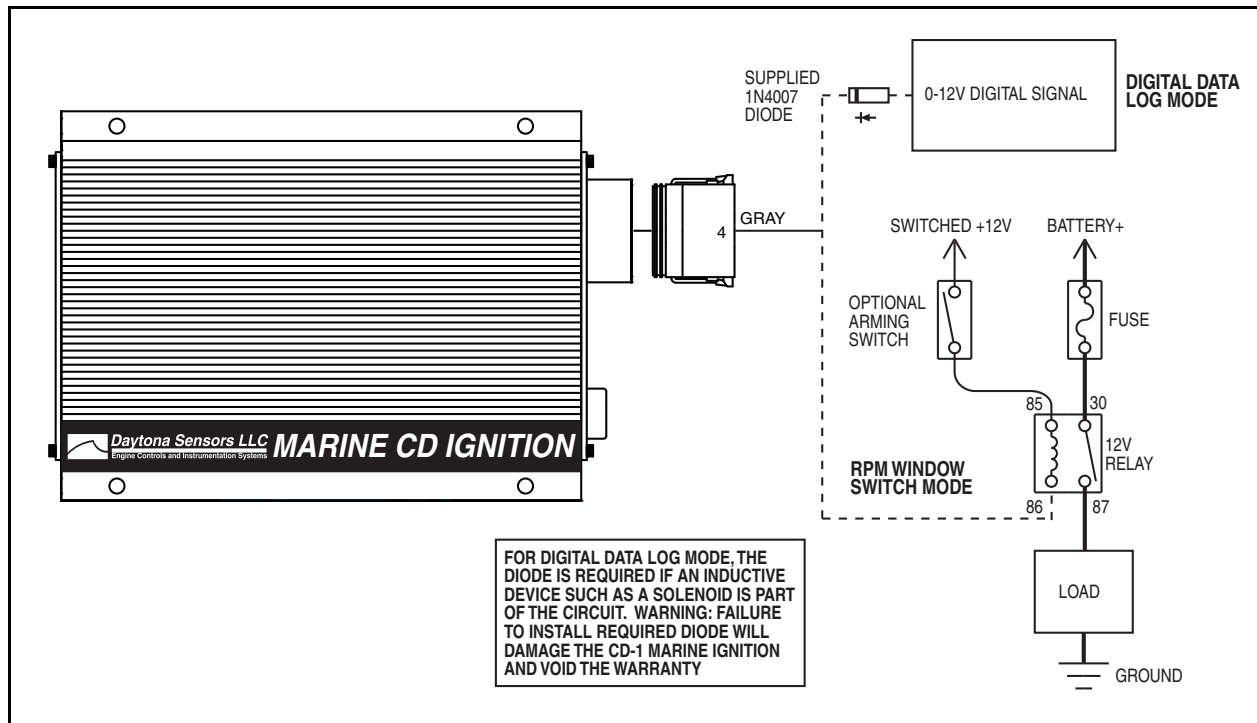
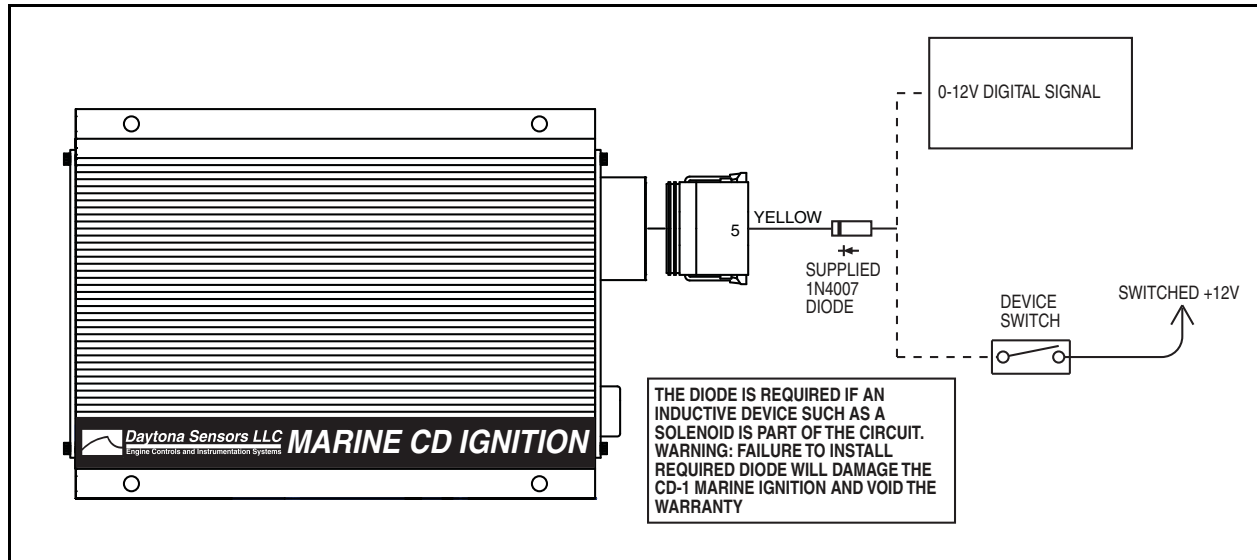

Figure 9 – GPIO3 Data Logging Hookup Options



MAP Sensor Hookup

A manifold absolute pressure (MAP) sensor is required for all applications that use a 3D timing table uploaded with the PC link.

The optional MAP sensor harness includes mating connector shells for Delphi 1 bar, 2 bar, and 3 bar MAP sensors (refer to the Appendix for recommended MAP sensor part numbers). Select the connector shell with the appropriate indexing features for your MAP sensor. Connect the ground, MAP signal, and +5V power wires as shown in Figure 5.

Retard Input Hookup

Figure 6 shows typical hookup of the external retard input. The retard feature is activated when the input is at +12V.

GPI1 Data Logging Hookup Options

Figure 7 shows data logging hookup options for GPI1. Both 0-5V analog signal levels and 0-12V digital off/on values are simultaneously logged by the CD-1. The on threshold voltage for digital signals is approximately 2.5V and the input is tolerant of voltage levels up to 30V. Many sensors have 0-5V signals levels and can be connected to GPI1. A +5V reference for sensor power (up to 50 ma current) is available at pin 10. To avoid errors caused by voltage drop between the CD-1 and engine ground, pin 8 can be used as the sensor ground. A switch or relay contact to +12V can be connected to GPI1 and logged as a digital signal.

GPIO2 Hookup Options

Figure 8 shows hookup options for GPIO2 modes that can be programmed by means of the PC link. Refer to page 19 for programming details.

1. **Digital data log mode.** This is the default for GPIO2 if no other mode is programmed. 0-12V digital off/on values are logged by the CD-1. The on threshold voltage for digital signals is approximately 2.5V and the input is tolerant of voltage levels up to 30V. A switch or relay contact to +12V can be connected to GPIO2 and logged as a digital signal.
2. **RPM window switch mode.** Connect a relay as shown to control a load. You can connect an optional arming switch as shown. For direct battery power connections, you should also install a fuse. Refer to the Appendix for recommended relays and fuses.

GPIO3 Data Logging Hookup Options

Figure 9 shows data logging hookup options for GPIO3. 0-12V digital off/on values are logged by the CD-1. The on threshold voltage for digital signals is approximately 2.5V and the input is tolerant of voltage levels up to 30V. A switch or relay contact to +12V can be connected to GPIO3 and logged as a digital signal.

WARNING: Failure to install the diodes shown in Figures 7-9 will damage the CD-1 and void the warranty.

SWITCH SETTINGS AND STATUS LED

The left end panel of the CD-1 has a status LED and five rotary switches used to set the RPM limit, timing curve, external retard value, and operating mode. The status LED will illuminate when the ignition switch is turned on. If a fault condition occurs, such as a DC/DC converter (internal high voltage power supply used to charge the capacitor) fault or loss of trigger signal, the status LED will blink.

RPM Limit Switch Settings

- 00 RPM limit disabled
- 01 RPM limit and multi-spark disabled
- 02 RPM limit, multi-spark, and timing functions disabled
- 03-04 Reserved (not used)
- 05 Boot load mode (used by factory to reprogram CD-1 module)
- 06-99 RPM limit setting X100 (i.e. switch setting 35 = 3,500 RPM)

Timing Curve Switch Settings

- 0 Fixed timing
- 1 Mercury HP 425-500 timing curve
- 2 Mercury HP 525SC timing curve
- 3 Mercury HP 600SC timing curve
- 4 Mercury HP 600SC Firepower timing curve
- 5 Mercury HP 800SC timing curve
- 6 General purpose timing curve for normally aspirated engines
- 7 General purpose timing curve with anti-stall feature for high performance engines
- 8-9 Reserved (not used)

Refer to the Appendix for details on the individual timing curves. Using the PC Link software to select a 2D or 3D timing table under module parameters overrides any setting of the timing curve switch. If you want to use fixed timing or one of the preset timing curves selected by the switch, click on the Disable Timing Table option.

Retard Switch Settings

When the retard input is activated by a +12V signal, ignition timing will be retarded by 2X the switch value (i.e. switch setting 4 = 8 degrees retard).

Mode Switch Settings

- 0 8 cylinder engine with trigger retard compensation disabled
- 1 8 cylinder engine with trigger retard compensation enabled
- 2-9 Reserved (not used)

Mode switch setting 1 is used during normal operation of the CD-1 and allows full functionality of any selections made with the PC Link software.

Figure 10 – Switches and Status LED

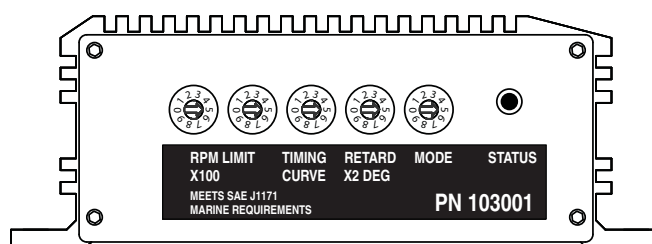

SPARK PLUGS AND WIRES

To avoid electrical noise that may interfere with the CD-1 or other onboard computer and radio equipment, resistor spark plugs are recommended and spiral core RFI/EMI suppression type spark plug wires are required. Optimum spark plug gap is .045" for normally aspirated engines. Engines with high boost levels may require a smaller spark plug gap. Do not use solid copper or high resistance carbon core spark plug wires. Optimum spark plug wire resistance is 50-500 ohms per foot, such as Taylor Vertex (www.taylorvertex.com) ThunderVolt 50 or 8.2mm spiral core.

APPLICATION ISSUES

1. **Tach hookup.** Some original equipment tachs require a high voltage pulse and will require a commercially available tach adapter.
2. **Ignition run-on.** If the engine continues to run after the ignition switch is turned off, current is leaking back into the CD-1 through the charging system. Please contact our tech support.

TROUBLESHOOTING

Did the engine run properly before installation of the CD-1? If not, remove the CD-1, reinstall the original ignition system and then find and correct the original problem. Did the CD-1 function correctly before the problem occurred? If the answer is yes, did you change anything that may have affected it? To isolate the problem, go back to the last setup that was OK. If the engine will not start, runs intermittently, or misfires, use the following check list steps:

Status LED Doesn't Illuminate

If the status LED doesn't illuminate after the ignition switch is turned on, check power and ground connections. Use a volt meter to verify +12V at the battery+ and ignition switch wires at the CD-1 with the ignition switch in both the run and start positions. The CD-1 requires a minimum of +9V when the ignition switch is first turned on. During cranking, the unit will continue to operate down to +4.5V.

Engine Will Not Start

If the status LED illuminates when the ignition switch is turned on but the engine will not start, verify that the status LED blinks while the engine is cranking. If the status LED doesn't blink during cranking, the unit is not getting a trigger signal. Verify that trigger signal wiring is not shorted together or to ground. If the status LED blinks, but engine will not start, recheck coil primary connections or replace coil.

Spark Testing

K-D Tools HEI ignition test plug P/N 2756 is recommended for spark testing. Attach the alligator clip on the test plug to chassis ground and fabricate a short section of spark plug wire to connect the test plug to the coil.

Intermittent Operation or Misfire at High RPM

1. Misfire at high RPM is usually not an electrical problem with the CD-1. Common causes include: coil failure or arcing at spark plug boots or within the distributor.

2. To avoid electrical noise problems, route magnetic trigger wiring away from any coil or spark plug wires. Use only spiral core spark plug wires. Do not use solid copper core or carbon core resistance wires.
3. Check for broken, loose or corroded connections. Verify correct air gap for magnetic pickup. Check distributor for loose, missing, or jammed parts in advance mechanism.
4. Verify that spark plugs are proper type, gap size, and heat range.
5. Replace spark plugs, spark plug wires, and distributor rotor and cap.

CD-1 SOFTWARE OVERVIEW

The Windows software suite for the CD-1 system consists of the PC Link CD Marine and CD Log programs. PC Link CD Marine allows you to set module parameters that control overall operation of the system and override certain switch settings, program the functions of the general purpose input/output (GPIO) terminals, and program advance curves. CD Log software allows you to download data from the CD-1 module, open and save files to disk, display data on a chart, and print chart graphics. Chart display for downloaded data allows you to monitor operation.

Note that the PC Link CD Marine software is a special marine version of the standard PC Link CD software used with the CD-1 automotive ignition. Do not use the standard PC Link CD software with the CD-1 marine ignition. The CD Log software supports both marine and automotive ignitions.

Use of the software programs is optional and not required for basic operation of the CD-1 system. If you are not planning on using the software, you can skip the rest of the material in this instruction manual.

PC REQUIREMENTS

The CD-1 connects to your PC by means of an optional USB interface P/N 102004. The PC must have a free USB port. If you have an older PC without USB capability, you cannot use the CD-1 software.

We recommend a laptop PC with Pentium processor and super VGA display (SVGA with 1024 x 768 pixel resolution) running Windows XP/Vista/7. Data chart display is graphics intensive and a high speed Pentium processor is recommended. Processors slower than 300 MHz will exhibit sluggish program loading and response. The PC must have a CDROM drive for program loading.

PC Link CD Marine and CD Log software include print commands to print downloaded data. The programs have been tested with Hewlett-Packard laser and inkjet printers and Epson inkjet printers. We recommend using a color inkjet printer.

USB INSTALLATION

The USB interface for the CD-1 is based on the FTDI FT232R chip and drivers that allow the unit to emulate a standard Windows RS-232 COM port. Updated Windows drivers, installation instructions and troubleshooting tips are available on the FTDI website at www.ftdichip.com. Additional information and troubleshooting tips can be found on the PC Link Tech FAQ on our website at www.daytona-sensors.com.

A new USB driver that simplifies the installation process is available. This installs as an executable file, similar to other Windows programs. The Windows Found New Hardware Wizard will then detect the USB device when it is first connected and automatically install the correct driver without the user having to browse out to the CDROM.

Before proceeding with installation, shutdown any other applications that may be running. For Windows Vista, you must disable the User Account Control (UAC) during installation. If you are not familiar with the UAC, please refer to the Vista UAC Tech Note on our website's PC Link Tech FAQ for details.

1. Make sure your USB interface is not connected to your PC. Please note that the USB interface does not need to be connected to the CD-1 during the USB installation process.
2. Insert the Daytona Sensors CDROM. When the Daytona Sensors autorun menu appears, click on Software. Scroll down and click on the USB Driver link. When the File Download dialog box appears, click on "Run this program from its current location." Ignore any security warnings and click on Yes to continue.
3. After installation of the driver is complete, connect the USB interface to the PC with the supplied USB cable. The Windows Found New Hardware Wizard will appear and complete installation of the USB interface.

COM Port Configuration

After completing the installation steps outlined above, you must configure the new COM port using Device Manager.

1. Click Start, Settings, Control Panel, System, Hardware, and then Device Manager. Scroll down to Ports (COM and LPT).
2. The new USB interface will appear as USB Serial Port. Click on this new port.
3. Click on the Port Settings tab.
4. Click on Advanced. In most cases the wizard will have installed your new USB interface as COM5. Note the COM port number assigned for your system. For optimum performance, you should also change the BM Options Latency Timer to 2 msec as shown in the Figure 11.
5. Once you have configured a COM port number for your new unit, make sure that you use this same COM port selection in the CD-1 software by using

the Port Setup command from the Communications menu.

Figure 11 – COM Port Configuration

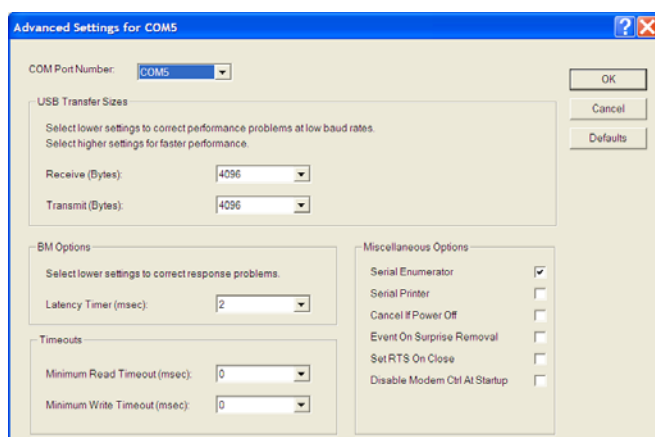

SOFTWARE INSTALLATION

The software is supplied on CDROM media or in the form of a compressed file downloaded from our website. The installation process uses InstallShield. This industry standard installer is based the new Microsoft Windows Installer service that greatly reduces potential problems such as version conflicts and allows for application self-repair.

There are two programs to install: PC Link CD Marine and CD Log. Start by installing PC Link CD Marine. If you are downloading software from the web, only download and install one program at a time. Before proceeding with installation, shutdown any other applications that may be running. For Windows Vista, you must disable the User Account Control (UAC) during installation. If you are not familiar with the UAC, please refer to the Vista UAC Tech Note on our website's Tech FAQ for details.

Use the Windows Explorer or the Run command from the Windows Start Menu to launch setup.exe in the PC_Link_CD_Marine folder on the CDROM or the setup.exe file downloaded from our website. InstallShield will install the software in an appropriate folder under Program Files.

Repeat the installation process for CD Log. Use the Windows Explorer or the Run command from the Windows Start Menu to launch setup.exe in the CD_Log folder on the CDROM or the setup.exe file downloaded from our website. InstallShield will install the software in an appropriate folder under Program Files.

Once InstallShield has completed the installation, PC Link CD Marine and CD Log will appear on the Windows Start Menu. You can then

launch them just as you would any other Windows program.

The programs require the Monospace 821 BT fixed pitch printer font in order to properly align columns when printing. The Monospace 821 BT font is included in the distribution media and automatically copied to your Windows Fonts folder during installation. A backup copy is also placed in the program folder. If you accidentally delete this font, use the Install New Font command from the Fonts folder File menu. The filename associated with Monospace 821 BT is monos.ttf.

PC LINK CD MARINE SOFTWARE

The brown tachometer wire (Deutsch connector pin 11) from the CD-1 is used connect to the USB interface. Mating single pin Packard Weather Pack connectors are supplied with the CD-1 to facilitate disconnecting the brown wire from the tachometer and connecting it to the USB interface as shown in Figures 1-3. PC communications is possible when the ignition is turned on and the engine has not yet been started. Once the engine is started, the brown wire resumes its normal function of driving the tachometer. Note that no damage occurs if the engine is inadvertently started while the USB interface is connected.

After PC Link CD Marine is launched, the main screen appears blank. You have three options for obtaining setup data for editing. You can open a previously saved setup file by using the Open Table command on the File menu. You can create a new setup file by using (as applicable) the Edit Module Parameters and Edit Idle Stabilization and GPIO Parameters commands from the Edit menu and the New Timing Table command on the File menu. You can also download data from an attached CD-1 module by using the Download From EEPROM command on the Communications menu.

Note that setup files use a .tbl extension. You should create a separate folder to store these files.

If you have enabled a 2D or 3D timing table under module parameters, you can use the Edit Timing Table command from the Edit menu. You can edit the timing table data by clicking on and dragging individual points on the chart display or you can directly edit numeric data on the spreadsheet grid.

Once the appropriate parameters and timing table data have been entered, you can print the data using the Print Parameters and Timing Table command on the Print Menu. You can save the edited setup file by using the Save Table command on the File menu.

You can upload the setup data to an attached CD-1 module by using the Upload to EEPROM command on the Communications menu.

A setup file (CD1_Marine_Sample.tbl) is included in the program folder.

DOWNLOADING DATA FROM EEPROM

Connect the USB interface. An adapter harness is supplied with the USB interface. Connect the alligator clip on the black wire to ground and the Packard Weather Pack connector to the brown tach wire from the CD-1 wire harness. If the tach wire is not equipped with a Weather Pack connector, you can use the supplied brown jumper wire with an alligator clip to make the required connection. **Set the switch on the USB interface to the "A" position.** Turn the ignition switch on to provide power to the CD-1. Do not start the engine.

When launched for the first time, the program uses COM1 as the default port. In most cases, you will have configured the USB interface to use a different COM port, such as COM5. Use the Port Setup command on the Communications menu to select the correct COM port. The program will remember the new port setup.

Download data by using the Download From EEPROM command on the Communications menu.

If the download process is successful, the module parameters are displayed. You can then edit setup data as explained in subsequent sections.

CD-1 units are shipped from the factory with default parameters and timing tables loaded into EEPROM memory. If you have never uploaded any custom setup file to EEPROM memory, these defaults are what you will see.

MODULE PARAMETERS

Module parameters are displayed in a dialog box by using the Edit Module Parameters command on the Edit menu. Module parameters control the overall operation of the CD-1 unit.

When PC Link CD Marine is first started, default module parameters are loaded. Module parameters are updated whenever you download data from a CD-1 unit or open a setup file. Module parameters are saved along with the GPIO parameters and timing table data when you save a setup file. **Always check the module parameters before uploading data to the CD-1.**

Figure 12 – Module Parameters

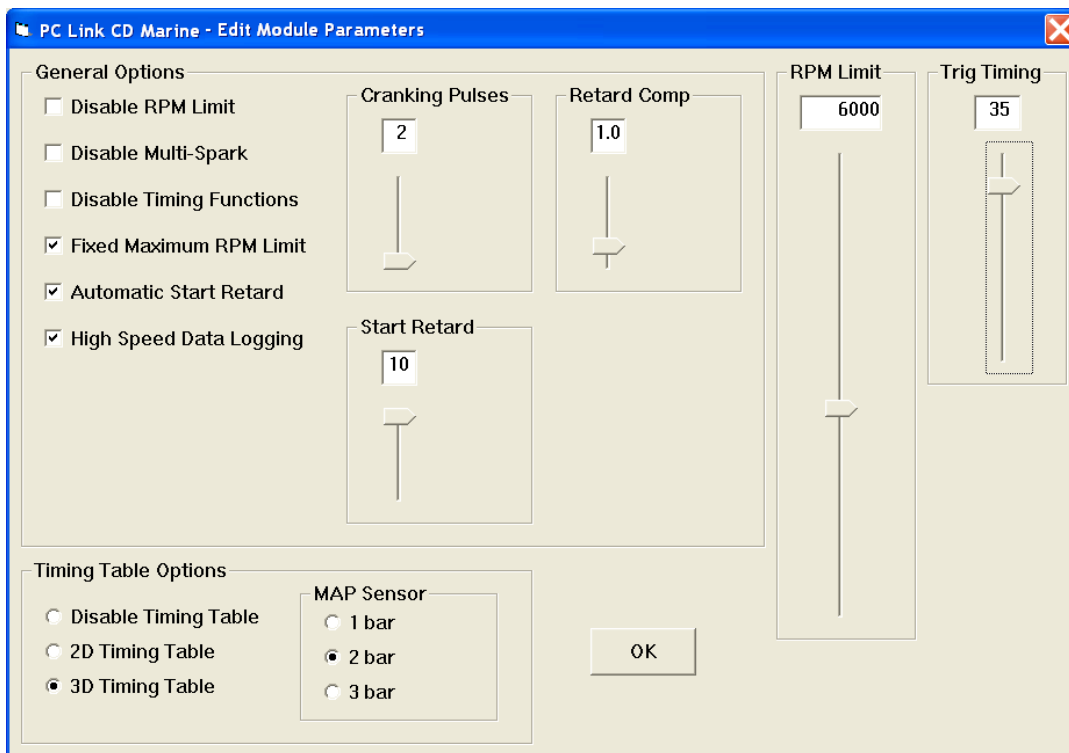

General Options

Disable RPM Limit - all RPM limit functions are disabled (including any fixed maximum RPM limit selection).

Disable Multi-Spark - multi-spark is disabled. Multi-spark should always be disabled when an external engine control that generates the trigger signal for the CD-1 also limits RPM. Missing trigger pulses could cause false multi-spark and result in cross-firing within the distributor.

Disable Timing Functions - all timing functions including the automatic start retard and any timing table are disabled.

Fixed Maximum RPM Limit - selecting this option overrides the RPM limit value set on the switches and the RPM limit slider is displayed.

Automatic Start Retard - selecting this option enables the automatic start retard and the start retard slider is displayed. You can set a start retard value from zero to 10 degrees. The automatic start retard is active for 10 engine revolutions after engine start while the engine is running below 450 RPM.

High Speed Data Logging - selecting this option enables high speed data logging at 100 samples/second. If high speed data logging is not enabled, the default data logging rate is 10 samples/second.

Cranking Pulses - the slider sets the number of trigger pulses (events) before the CD-1 fires the first spark. For a V8 engine, there are 4 trigger pulses per revolution. To prevent spurious firing when the ignition key is turned on, you should always use a value of 2 or higher.

Retard Comp - the slider allows fine tuning the timing to eliminate the effects of spark firing delay and the intrinsic delay of some magnetic pickup systems. A typical value is 1.5 degrees. Check the timing with a timing light. If a noticeable retard is observed between 2,000 RPM and the upper RPM range of the engine, use a higher value for retard compensation.

Timing Table Options

Disable Timing Table - no timing table is active.

2D Timing Table - enables a 2D timing table with timing based on engine RPM.

3D Timing Table - enables a 3D timing table with timing based on engine RPM and manifold absolute pressure (MAP). The MAP sensor option box appears. You can select a 1 bar, 2 bar, or 3 bar MAP sensor. To

use the 3D timing table, a MAP sensor must be connected. Refer to Figure 5 and page 9 for details.

Trigger Timing

The CD-1 and similar competitive products require a trigger signal (magnetic pickup or 12V module output) with a single pulse per firing event. The rising edge of the trigger pulse is the most advanced timing (earliest spark firing) that the unit can generate. All timing curves and other timing functions are based on retarding the spark firing referenced to the trigger pulse.

Set the Trig (Trigger) Timing slider value to correspond to the actual advanced timing point (degrees BTDC) of your trigger signal. The trigger timing value represents the most advanced timing that the CD-1 can generate. The default value is 30 degrees BTDC, but you must enter the actual value for your engine (or adjust your trigger system so that it generates a trigger signal at 30 degrees BTDC).

Timing table data "tracks" the trigger timing value. The table values always represent the actual engine timing that will result if the trigger system generates a pulse corresponding to the trigger timing value.

IDLE STABILIZATION AND GENERAL PURPOSE INPUT/OUTPUT PARAMETERS

Idle stabilization and general purpose input/output (GPIO) parameters are displayed in a dialog box by using the Edit Idle Stabilization and GPIO Parameters command on the Edit menu. Idle stabilization is useful for some applications where the engine tends to stall when put into gear. GPIO parameters control the function of the GPIO2 terminal on the CD-1 unit. Note that for the CD-1 Marine

Ignition, the GPI1 and GPIO3 terminals are currently used for data logging only.

When PC Link CD Marine is first started, default idle stabilization and GPIO parameters are loaded. The parameters are updated whenever you download data from a CD-1 unit or open a setup file. These parameters are saved along with the module parameters and timing table data when you save a setup file. **Always check the idle stabilization and GPIO parameters before uploading data to the CD-1.**

Figure 13 – Idle Stabilization and GPIO Parameters

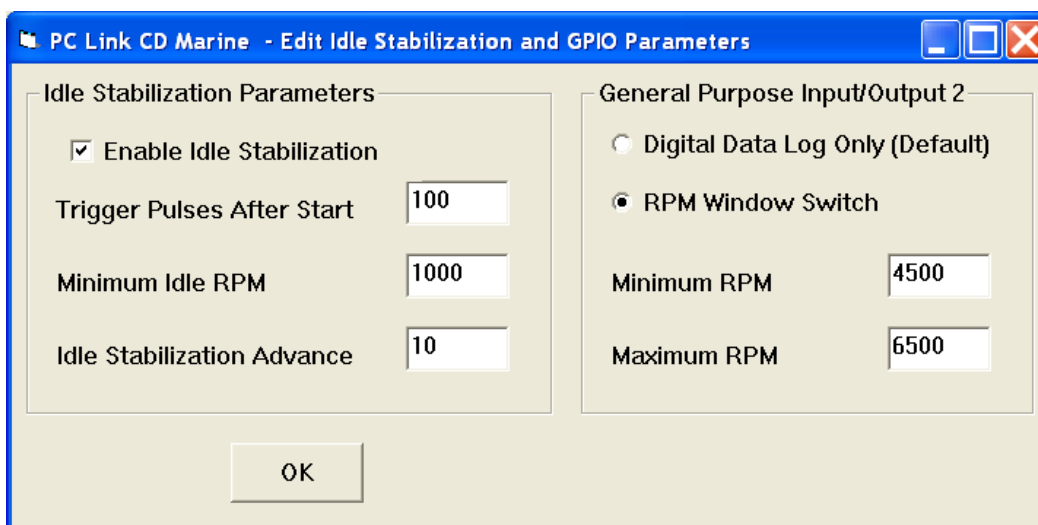

Idle Stabilization

When enabled, the idle stabilization feature becomes active after the selected number of trigger pulses after engine start.

The idle stabilization feature advances ignition timing below the minimum idle RPM. When engine speed drops below the minimum idle RPM, the idle stabilization advance value is added to the normal advance table value. This increases engine output and RPM.

Note that idle stabilization can only function when a timing curve (timing curve switch settings 1-7, but not zero for fixed timing) or PC Link programmed 2D or 3D timing table is active. Since trigger timing represents the most advanced timing the CD-1 can generate, the idle stabilization advance added to the applicable timing advance at idle cannot exceed the trigger timing value.

General Purpose Input/Output 2 (GPIO2)

GPIO2 is on the Deutsch connector pin 4. When configured as an output, GPIO2 can switch a 2 amp load to ground. A relay must be used to control larger loads, such as solenoid valves. GPIO2 has five modes:

Data Log Only - the system will log data on GPIO2. You can log a digital signal with zero and +12V levels.

RPM Window Switch - the GPIO2 output will be active (switched to ground) whenever engine RPM is within the minimum and maximum values.

CREATING A NEW TIMING TABLE

If you are creating a new setup file, you must first select the 2D or 3D timing table option under module parameters as explained in the Module Parameters section. You can then use the New Timing Table command on the File menu. A dialog box appears as shown in Figure 14 or 15 depending on the type of timing table you selected.

Figure 14 – New 2D Timing Table Dialog

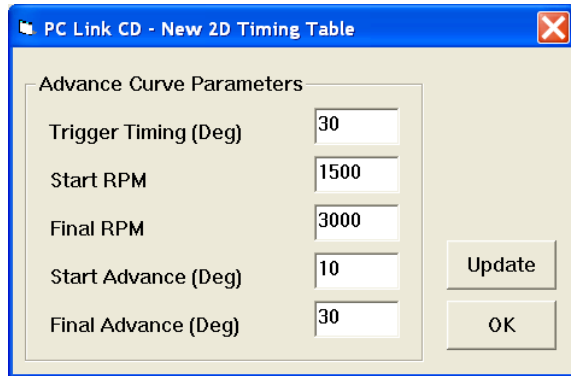

New 2D Timing Table

For a new 2D timing table, you can enter the trigger timing, start and final RPM, and start and final advance. A new value of trigger timing overrides and updates whatever value you may have previously entered under module parameters. Set the trigger timing value to correspond to the actual advanced timing point (degrees BTDC) of your trigger signal. The trigger timing value represents the most advanced timing that the CD-1 can generate. The default value is 30 degrees BTDC, but you must enter the actual value for your engine (or adjust your trigger system so that it generates a trigger signal at 30 degrees BTDC). Trigger timing is shown on the graph as a straight blue line. The actual timing advance curve is shown in red. Since trigger timing represents the most advanced timing, the red timing curve can never go above the blue trigger timing line. The total timing range of the CD-1 is limited to 22 degrees to prevent possible crossfiring into the next cylinder. For example, if you set trigger timing to 30 degrees, the actual advance range is 8.0 to 30 degrees. The program will not allow you to enter values outside this range.

Each time you click on Update, the corresponding timing advance table is displayed. You will find the New Timing Table command useful for generating a timing advance table that will serve as a starting point for further edits. When you are ready to proceed with editing, click on OK.

Figure 15 – New 3D Timing Table Dialog

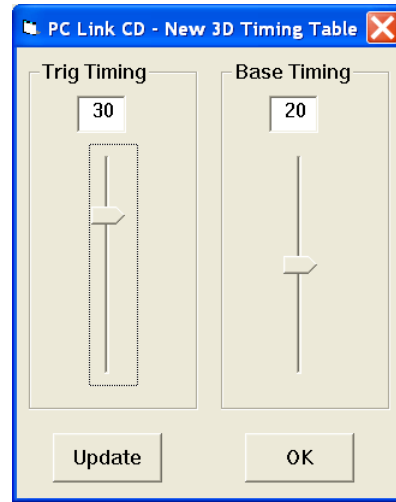

New 3D Timing Table

For a new 3D timing table, you can enter the trigger timing and a base timing value. The base timing value is used to generate a flat timing table. A new value of trigger timing overrides and updates whatever value you may have previously entered under module parameters. Set the trigger timing slider to correspond to the actual advanced timing point (degrees BTDC) of your trigger signal. The trigger timing value represents the most advanced timing that the CD-1 can generate. The default value is 30 degrees BTDC, but you must enter the actual value for your engine (or adjust your trigger system so that it generates a trigger signal at 30 degrees BTDC). Since trigger timing represents the most advanced timing, the 3D timing table values can never exceed the trigger timing. The total timing range of the CD-1 is limited to 22 degrees to prevent possible crossfiring into the next cylinder. For example, if you set trigger timing to 30 degrees, the actual advance range is 8.0 to 30 degrees. The program will not allow you to enter values outside this range.

Each time you click on Update, the corresponding timing advance table is displayed. You will find the New Timing Table command useful for generating a timing advance table that will serve as a starting point for further edits. When you are ready to proceed with editing, click on OK.

EDITING TIMING TABLE DATA

Once you have timing advance table data, you can edit the data by clicking on and dragging individual points on the chart display or you can directly edit numeric data on the spreadsheet grid.

2D Timing Table

The table consists of 21 columns corresponding to 500 RPM increments from zero to 10,000 RPM. The 10,000 RPM timing value is used at all higher RPM levels.

The trigger timing value represents the most advanced timing that the CD-1 can generate. The default value is 30 degrees BTDC, but you must use the actual value for your engine (or adjust your trigger system so that it generates a trigger signal at 30 degrees BTDC). If you need to change the trigger timing value, go back to module parameters. Trigger

timing is shown on the graph as a straight blue line. The actual timing advance curve is shown in red. Since trigger timing represents the most advanced timing, the red timing curve can never go above the blue trigger timing line. The total timing range of the CD-1 is limited to 22 degrees to prevent possible crossfiring into the next cylinder. For example, if you set trigger timing to 30 degrees, the actual advance range is 8.0 to 30 degrees. The program will not allow you to enter values outside this range.

There is a slight signal delay within the CD-1 unit. This affects the maximum advance that can be generated at high RPM. You should leave about 1 degree headroom between the maximum advance value on your table and the CKP timing value. For example, if your CKP timing is 30 degrees, you should not use timing table values exceeding 29 degrees above 3,000 RPM.

Figure 16 – 2D Timing Table



PC Link CD Marine is intended to be an open system and uses the Component One Chart 7.0 2D charting control. The adventurous user can experiment with the chart property pages by right clicking on the chart. Almost any chart property can be changed. Click on the Help button for more information. If you corrupt the chart, exit and restart PC Link CD.

3D Timing Table

The 3D timing advance table consists of 21 columns corresponding to 500 RPM increments from zero to 10,000 RPM and 8 manifold pressure (MAP) rows. The MAP range depends on the type of MAP sensor selected under module parameters. The timing value at 10,000 RPM is used at all higher RPM levels and the timing value in the lowest MAP row is used at all lower MAP levels. Note that 30 In-Hg corresponds to atmospheric pressure (zero boost). Normally aspirated engines will not exceed 30 In-Hg and not all supercharged engines will reach the maximum MAP level for 2 bar or 3 bar MAP sensors. You can use the CD Log software to check the actual MAP values when the engine is running under various load and throttle settings.

The trigger timing value represents the most advanced timing that the CD-1 can generate. The default value is 30 degrees BTDC, but you must use

the actual value for your engine (or adjust your trigger system so that it generates a trigger signal at 30 degrees BTDC). If you need to change the trigger timing value, go back to module parameters. Since trigger timing represents the most advanced timing, the 3D timing table values can never go exceed the trigger timing. The total timing range of the CD-1 is limited to 22 degrees to prevent possible crossfiring into the next cylinder. For example, if you set trigger timing to 30 degrees, the actual advance range is 8.0 to 30 degrees. The program will not allow you to enter values outside this range.

There is a slight signal delay within the CD-1 unit. This affects the maximum advance that can be generated at high RPM. You should leave about 1 degree headroom between the maximum advance value on your table and the CKP timing value. For example, if your CKP timing is 30 degrees, you should not use timing table values exceeding 29 degrees above 3,000 RPM.

Figure 17 – 3D Timing Table

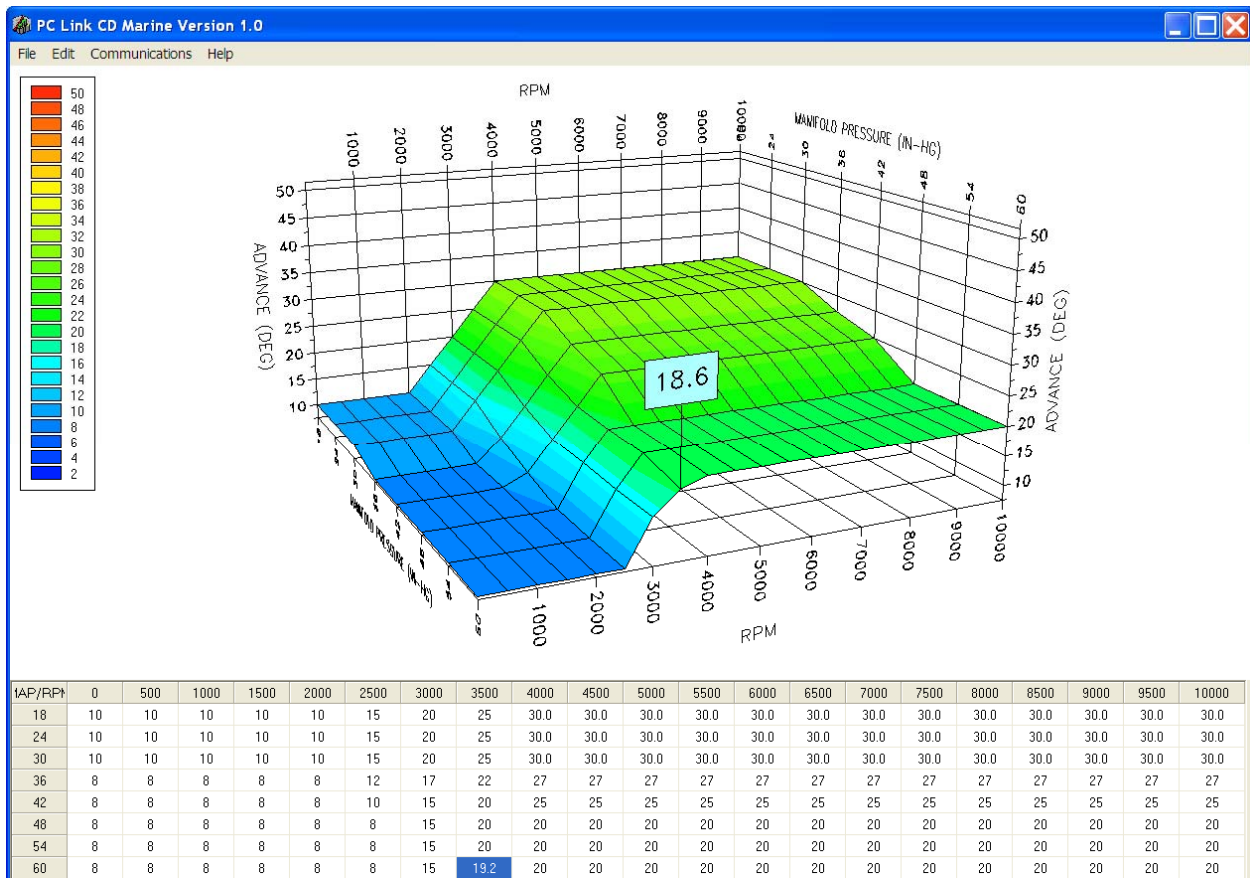

You can rotate the 3D chart display for a better view of a particular region by dragging the mouse while holding both mouse buttons down. PC Link CD Marine is intended to be an open system and uses the Component One Chart 7.0 3D charting control. The adventurous user can experiment with the chart property pages by right clicking on the chart. Almost any chart property can be changed. Click on the Help button for more information. If you corrupt the chart, exit and restart PC Link CD Marine.

Editing Spreadsheet Table Data

You can edit table data using standard Windows copy and paste operations by selecting cells and then clicking the right mouse button to pop-up the edit menu. You can select cells by dragging the mouse with the left button down. You can also use the Modify command on the pop-up menu. When you enter a value, the presence of optional sign (+ or -) or percent (%) characters affects the outcome of the Modify command.

Figure 18 – Modify Command

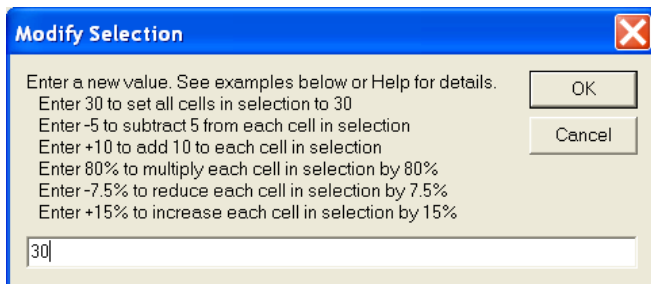

Data Export and Import by Means of Copy and Paste

You might want to export or import table data to or from another application such as Microsoft Excel and other programs with tables that support copy and paste operations. You can directly copy and paste data to and from the PC Link CD Marine program. In the PC Link CD Marine program, you can select a range of cells with the mouse and right click to bring up a copy and paste menu. When you paste data into the PC Link CD Marine program, the data is automatically checked and any out-of-range data corrected.

UPLOADING DATA TO EEPROM

Refer to the Downloading Data from EEPROM section on page 14 for details about USB interface cable hookup and COM port setup. Before uploading, make sure the parameters and timing tables are correct.

Upload data by using the Upload To EEPROM command on the Communications menu. A status message is displayed when the upload process has been successfully completed.

TRIGGER TIMING CONSIDERATIONS

The trigger timing value set under module parameters must correspond to the actual advanced timing point (degrees BTDC) of your trigger signal. The trigger signal can come from a magnetic pickup crankshaft position sensor, magnetic distributor pickup, or 12V module trigger signal from another system such as an electronic engine control module (ECM). The trigger timing value represents the most advanced timing that the CD-1 can generate. The default value is 30 degrees BTDC, but you must enter the actual value for your engine (or adjust your trigger system so that it generates a trigger signal at 30 degrees BTDC). Since trigger timing represents the most advanced timing, the timing table values can never exceed the trigger timing. The total timing range of the CD-1 is limited to 22 degrees to prevent possible crossfiring into the next cylinder. For example, if you set trigger timing to 30 degrees, the actual advance range is 8.0 to 30 degrees.

The trigger timing value is also used by the CD Log data logging software to allow correct display of timing advance.

Magnetic Pickup Crankshaft Position (CKP) Sensor

You can accurately establish the position of the CKP sensor by temporarily disabling multi-spark and any timing table in module parameters (remember to upload to CD-1). Use a timing light to check the timing and adjust the position of the CKP sensor as required so that your observed engine timing is the same as the trigger timing value. For best accuracy, we suggest that you set the timing at 1,500-2,000 RPM. While you are conducting this test, you should also check the distributor phasing. Use a spare distributor cap and drill or mill a large hole on the top or side so that you can observe the rotor tip position at cylinder 1 with the timing light. If you are using a dial-back timing light, set the dial-back to zero while observing rotor tip position. The leading edge of the rotor should just touch the cap terminal.

Magnetic or Mercury Hall Effect Pickup Distributor without Advance Mechanism

You can accurately establish the position of the distributor by temporarily disabling multi-spark and any timing table in module parameters (remember to upload to CD-1). Use a timing light to check the timing and adjust the position of the distributor as required so that your observed engine timing is the same as the trigger timing value. For best accuracy, we suggest that you set the timing at 1,500-2,000 RPM.

Mercury Hall effect distributors will require our P/N 103004 marine rotor or modification of the existing rotor using the template in the Appendix for proper phasing.

Magnetic Pickup Distributor with Advance Mechanism

In this case, you will not be using a timing table, but you might still want to use the retard features and data logging. Set the trigger timing value to correspond to the maximum distributor advance at high RPM.

Module Trigger from an ECM

In this case, you will not be using a timing table, but you might still want to use the retard features and data logging. Set the trigger timing value to correspond to the maximum advance generated by the ECM at high RPM.

CD LOG SOFTWARE

The CD Log software supports both marine and automotive ignitions. When used with the CD-1 Marine, certain selections, such as vehicle speed, are either grayed out or not applicable.

The brown tachometer wire (Deutsch connector pin 11) from the CD-1 is used connect to the USB interface. Mating single pin Packard Weather Pack connectors are supplied with the CD-1 to facilitate disconnecting the brown wire from the tachometer and connecting it to the USB interface as shown in Figures 1 and 2. PC communications is possible when the ignition is turned on and the engine has not yet been started. Once the engine is started, the brown wire resumes its normal function of driving the tachometer. Note that no damage occurs if the engine is inadvertently started while the USB interface is connected.

When launched for the first time, the program uses COM1 as the default port. In most cases, you will have configured the USB interface to use a different COM port, such as COM5. Use the Port Setup command on the Communications menu to select the correct COM port. The program will remember the new port setup.

After CD Log is launched, the screen initially appears blank. You can use the Units Selection command from the Edit menu to pressure units if your CD-1 is configured to log this data, i.e. a manifold absolute pressure (MAP) sensor connected. The program will remember your selections. You can display data logged by the unit on a chart recorder type screen. Data logged by the unit must be downloaded before it can be displayed, by using the Download Data command on the Communications menu. Once data has been downloaded, it is automatically displayed on a chart recorder type screen. You can save downloaded data by using the Save File command from the File menu. You can display a previously saved data file by first using the Open File command on the File menu and then using the View Chart command on the View menu.

A sample data file (CD1_Sample.log) is included in the program folder. Note that this data is from an automotive drag race session, but is useful for illustrating the capabilities of the software.

UNITS SELECTION

You can use the Units Selection command from the Edit menu to select pressure units if your CD-1 is configured to log this data, i.e. a manifold absolute

pressure (MAP) sensor connected. Note that the speed units selection is not applicable to marine ignitions. The program will remember your selections. When you save downloaded data to a file, the units settings are saved along with the data. If you later open the file, the same units settings will remain in effect.

Figure 20 – Units Selection Dialog Box

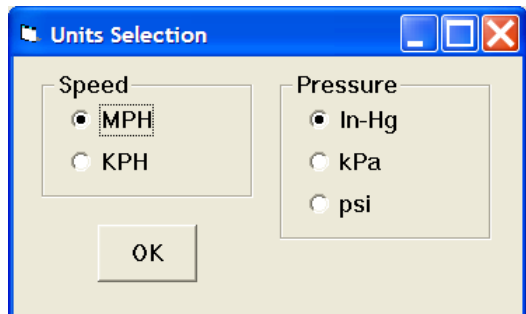

DOWNLOADING DATA

Connect the USB interface. An adapter harness is supplied with the USB interface. Connect the alligator clip on the black wire to ground and the Packard Weather Pack connector to the brown tach wire from the CD-1 wire harness. If the tach wire is not equipped with a Weather Pack connector, you can use the supplied brown jumper wire with an alligator clip to make the required connection. **Set the switch on the USB interface to the "A" position.** Turn the ignition switch on to provide power to the CD-1. Do not start the engine.

When launched for the first time, the program uses COM1 as the default port. In most cases, you will have configured the USB interface to use a different COM port, such as COM5. Use the Port Setup command on the Communications menu to select the correct COM port. The program will remember the new port setup.

Download data by using the Download Data command on the Communications menu.

DATA LOGGING CHART DISPLAY

You can display data logged by the unit on a chart recorder type screen. Data logged by the unit must be downloaded before it can be displayed, by using the Download Data command on the Communications menu. Once data has been downloaded, it is automatically displayed. **The last data logged will appear at the right end of the chart.** You can save the data by using the Save File command from the File menu. You can display a previously saved data file by first using the Open File

command on the File menu and then using the View Chart command on the View menu.

The data logging memory within the CD-1 stores the **last** 18000 data points at 10 samples/second (default sample rate) or 100 samples/second (if the high speed data logging mode is selected by means of the PC Link CD Marine software). This corresponds to 5 hours of data at 10 samples/second or 30 minutes of data at 100 samples/sec. When you use the Download Data command on the Communications menu, one of the popup menus shown below will appear based on the sampling rate you have configured. You can select the length of the data set that will be downloaded.

Figure 21 – Download Options Dialog Box (CD-1 Configured for 10 Samples/Second)

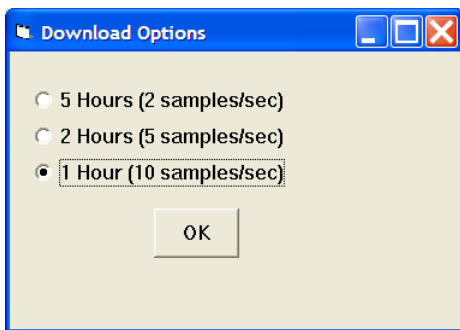
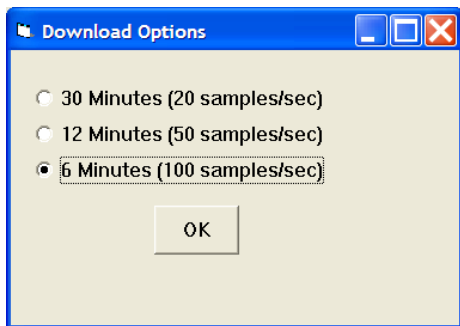

Figure 22 – Download Options Dialog Box (CD-1 Configured for 100 Samples/Second)



Note that CD-1 data files use a .log extension. You should create a separate folder to store these files. A sample data file (Sample.log) is included in the program folder. You have a range of capabilities for analyzing downloaded data displayed in the chart recorder format.

You can select two parameters for display. Trace 1 is displayed in red with its Y axis legends on the left side of the chart. Trace 2 is displayed in green with its Y axis legends on the right side of the chart. The X axis is always elapsed time. You can zoom in,

zoom out, or zoom all (displays entire data file). At the maximum zoom in level, approximately 100 data samples will be displayed on the chart. You can use the scroll bar to move the chart display window in terms of elapsed time. If you hold the left mouse button down within the chart area, a cursor line appears. The exact values of the parameters displayed on trace 1 and trace 2 and the elapsed time appear in windows above the chart. When you zoom in or zoom out, the displayed data will always be centered about the cursor line. This allows you to quickly select and closely examine an area of interest. If you want to analyze the elapsed time between two events (for example the time required to accelerate from 0 to 60 MPH), you can move the cursor to the first event and then click on the Reset Time Display button. You can print the displayed chart to any Windows printer by clicking on the Print button (a color inkjet printer is recommended for best results). Data parameters include:

RPM – engine crankshaft RPM

TIMING – ignition advance in degrees BTDC

MAP – manifold pressure in In-Hg, kilopascals (kPa), or psi (29.92 In-Hg, 101.3 kPa, or 14.696 psi corresponds to sea level atmospheric pressure). If a MAP sensor is not connected, the MAP value corresponding to zero sensor volts will be displayed. The CD-1 supports standard Delphi 1 bar, 2 bar, and 3 bar MAP sensor as configured with the PC Link CD Marine software.

BAT – battery voltage

GPI1 ANALOG – zero to +5V analog input voltage on the GPI1 input (Deutsch connector pin 3)

RETARD IN – input level on Deutsch connector pin 2 displayed as a digital (on/off) signal

GPI1 DIGITAL – input level on the GPI1 terminal displayed as a digital (on/off) signal. On means that the GPIO is terminal is at +12V

GPI02, GPI03 – the GPIO2 terminal on Deutsch connector pin 4 can be configured for various functions with the PC Link CD Marine software. When configured as an input, the level is displayed as a digital (on/off) signal. On means that the GPIO terminal is at +12V. When configured as output, the status is also displayed as a digital (on/off) signal. On means that the GPIO terminal is switched to ground. This is referred to as an active low output. GPIO3 is always an input. On means that the GPIO3 is terminal is at +12V

The maximum RPM value displayed on the chart can be set by means of a command on the Chart Display Edit Menu. **Caution: If the maximum value is set lower than the actual logged data, the chart cursor function will not update the display correctly.**

Additional data is displayed at the lower right side of the screen. This data includes:

Status - displays CD-1 status

Diagnostic Code – normally blank unless a diagnostic code is set.

Log Interval – the actual data logging interval in seconds

You can clear the data within the unit by using the Clear CD-1 Data Buffer command from the Communications menu. If you change the data logging mode with the PC Link CD Marine software, you should also clear the data buffer within the unit.

Figure 23 – Data Logging Chart Display

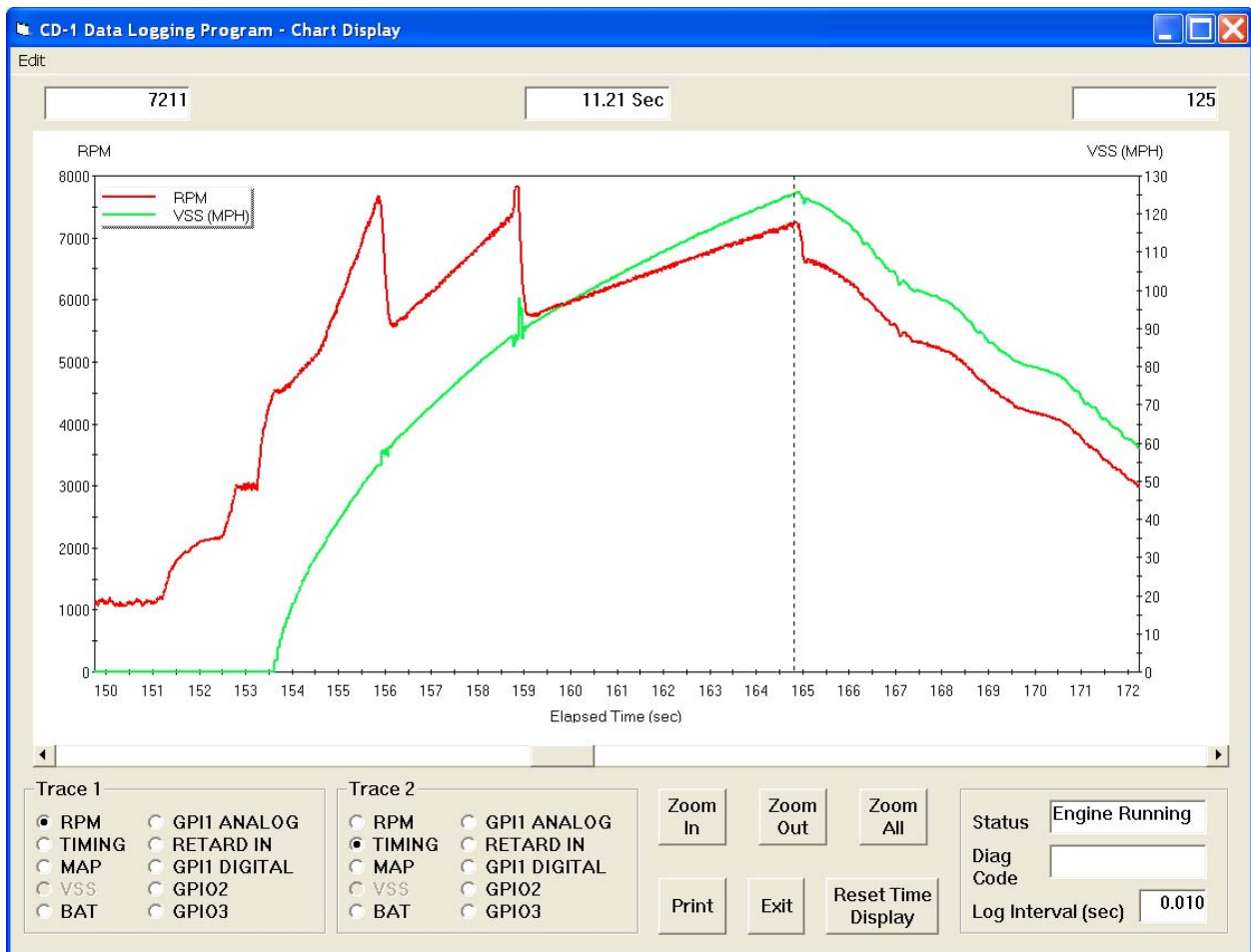

IMPORTING DATA INTO EXCEL

Data files saved from CD Log are in comma delimited ASCII format. Note that VSS data is scaled in MPH units and MAP data is scaled in In-Hg units. You can easily import a data file into other programs such as Microsoft Excel for further analysis. You can also view data files with a text editor such as Windows WordPad. To import a data file into Excel:

1. Start Excel. In the File Open dialog box, select Files of type: All Files (*.*). Then browse for the data file.
2. The Text Import Wizard appears. For step 1, select delimited file type. For step 2, select comma delimiter. For step 3, select general column data format. Then click on Finish.
3. You can then format the data and save the spreadsheet as an Excel file.

APPENDIX – TIMING CURVES

MERCURY HP425-500 TIMING CURVE

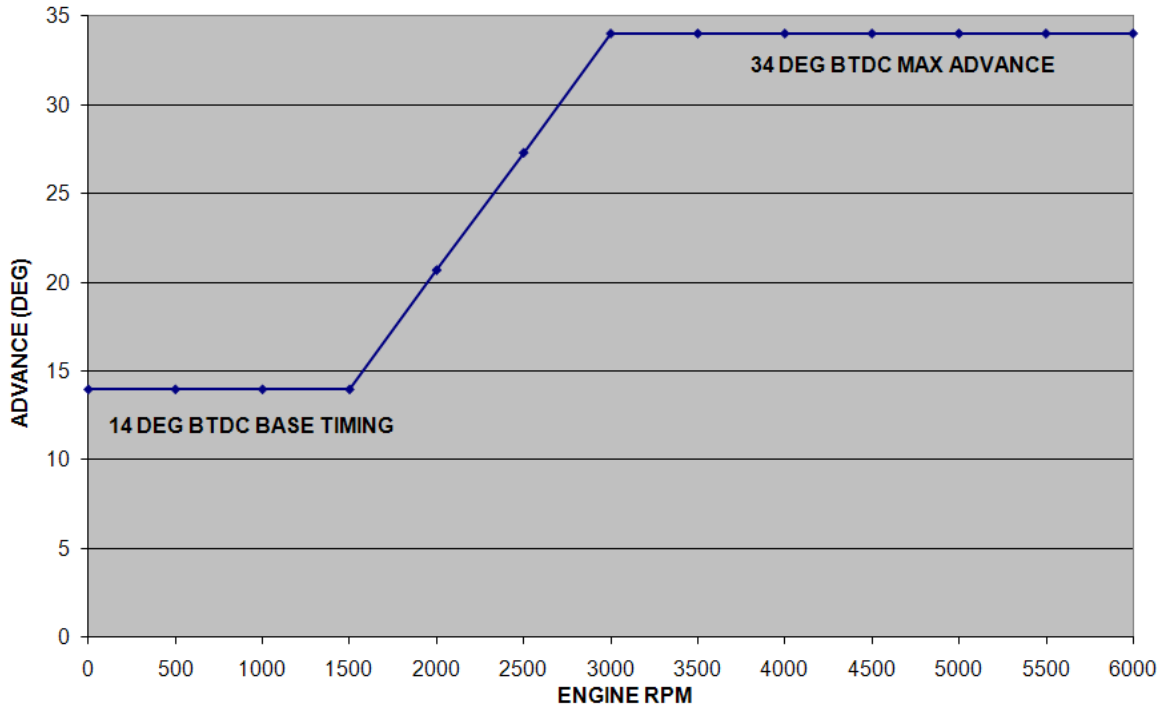

MERCURY HP525SC TIMING CURVE

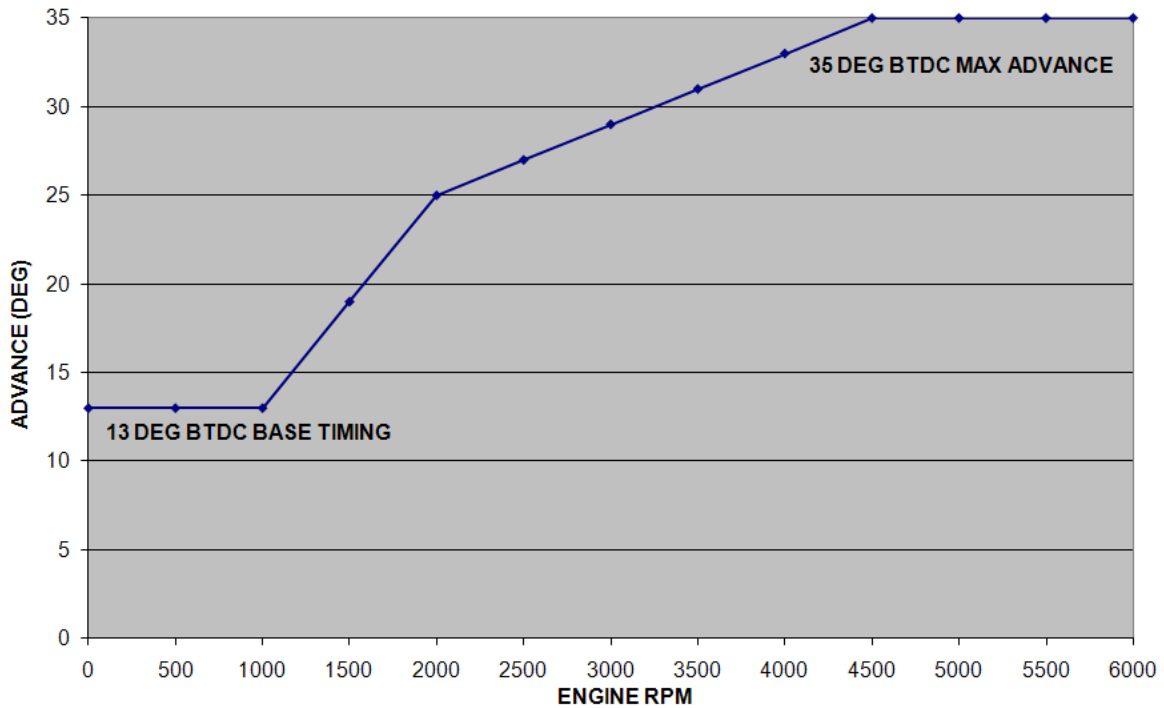

MERCURY HP600SC TIMING CURVE

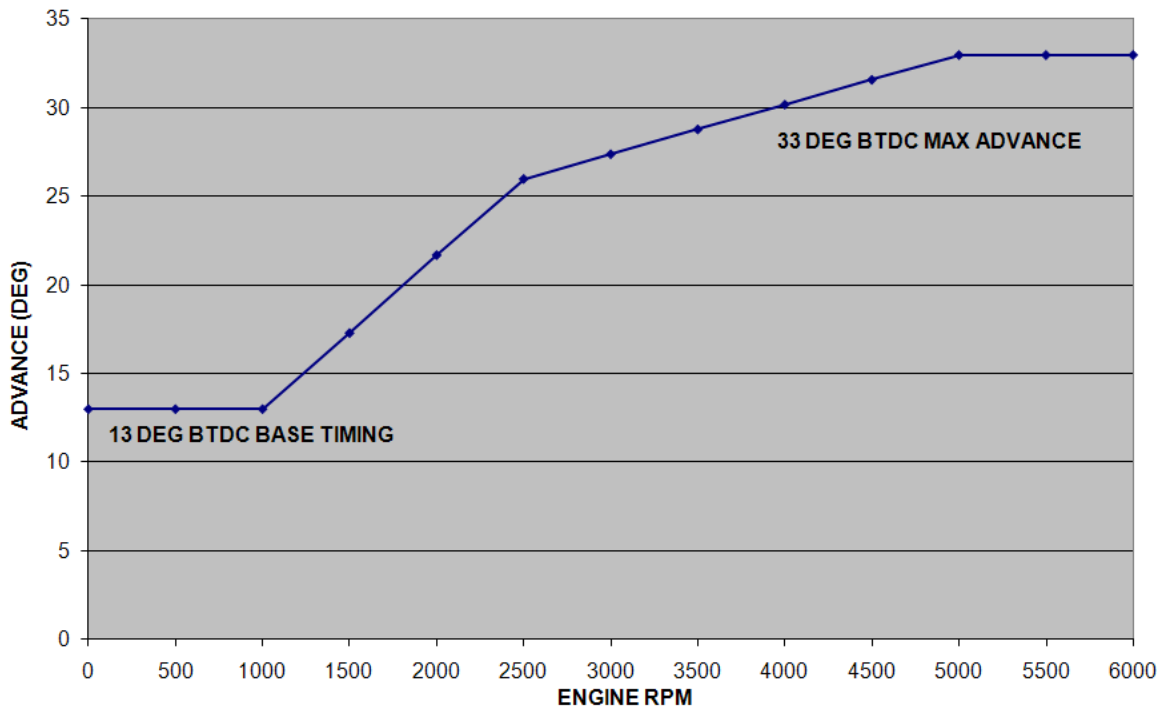

MERCURY HP600SC FIREPOWER TIMING CURVE

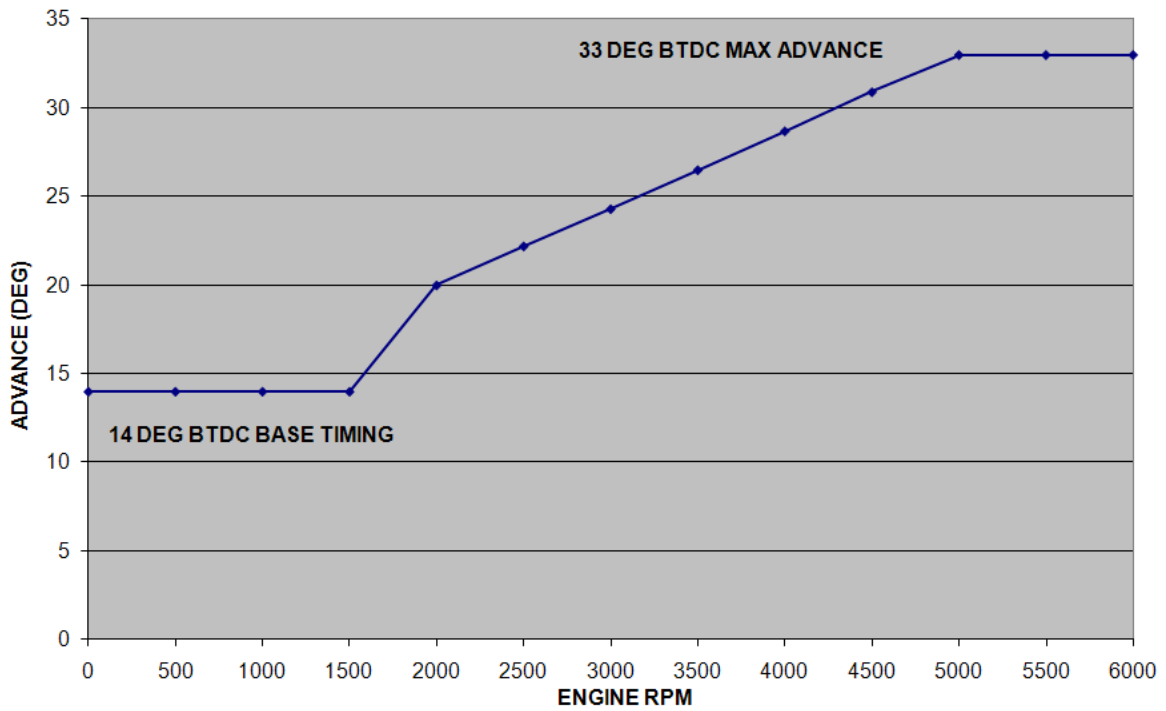

MERCURY HP800SC TIMING CURVE

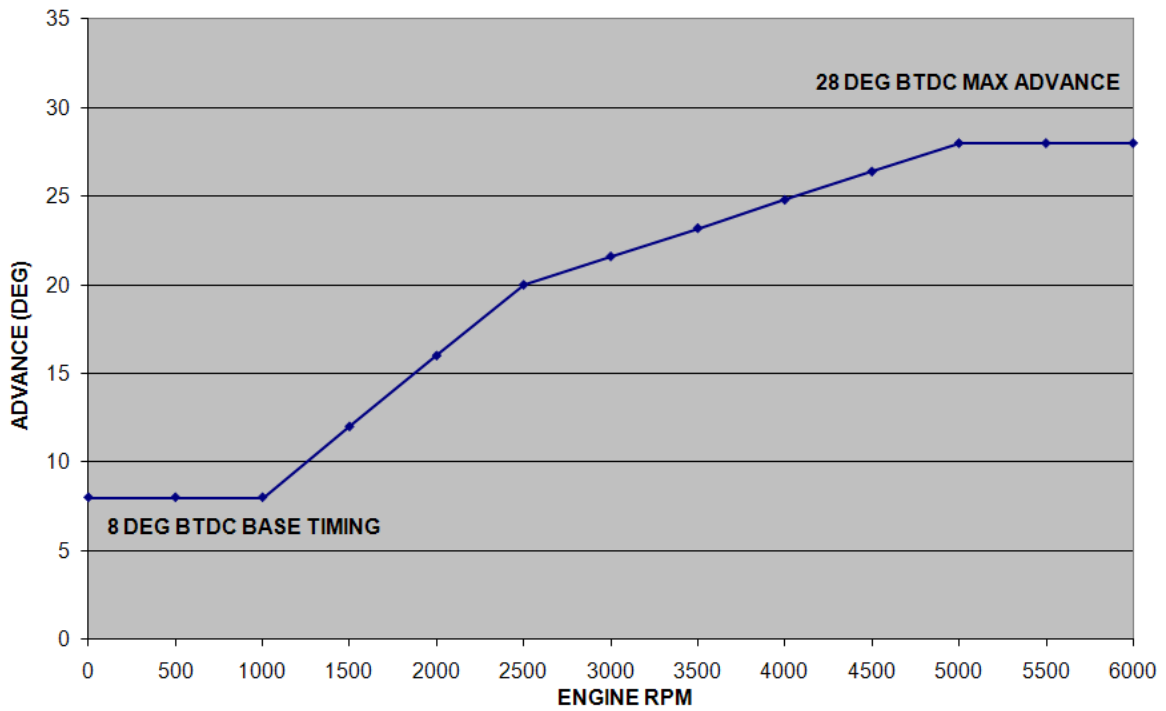

NORMALLY ASPIRATED ENGINE TIMING CURVE

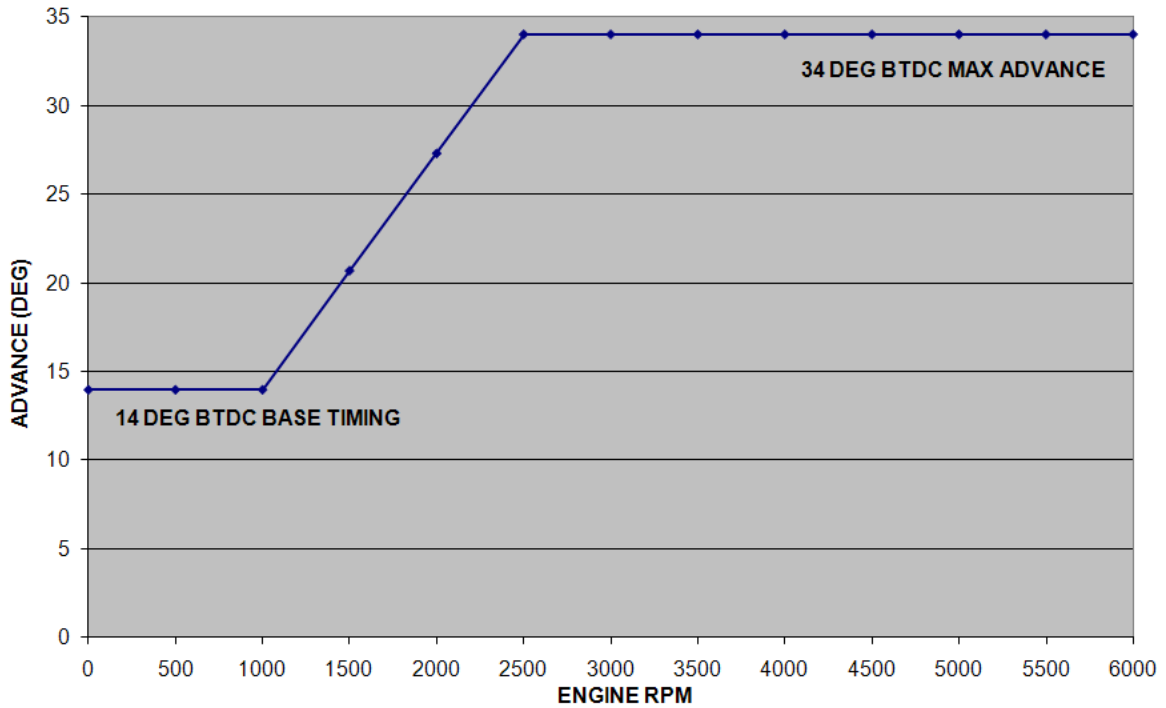

NORMALLY ASPIRATED ENGINE ANTI-STALL TIMING CURVE

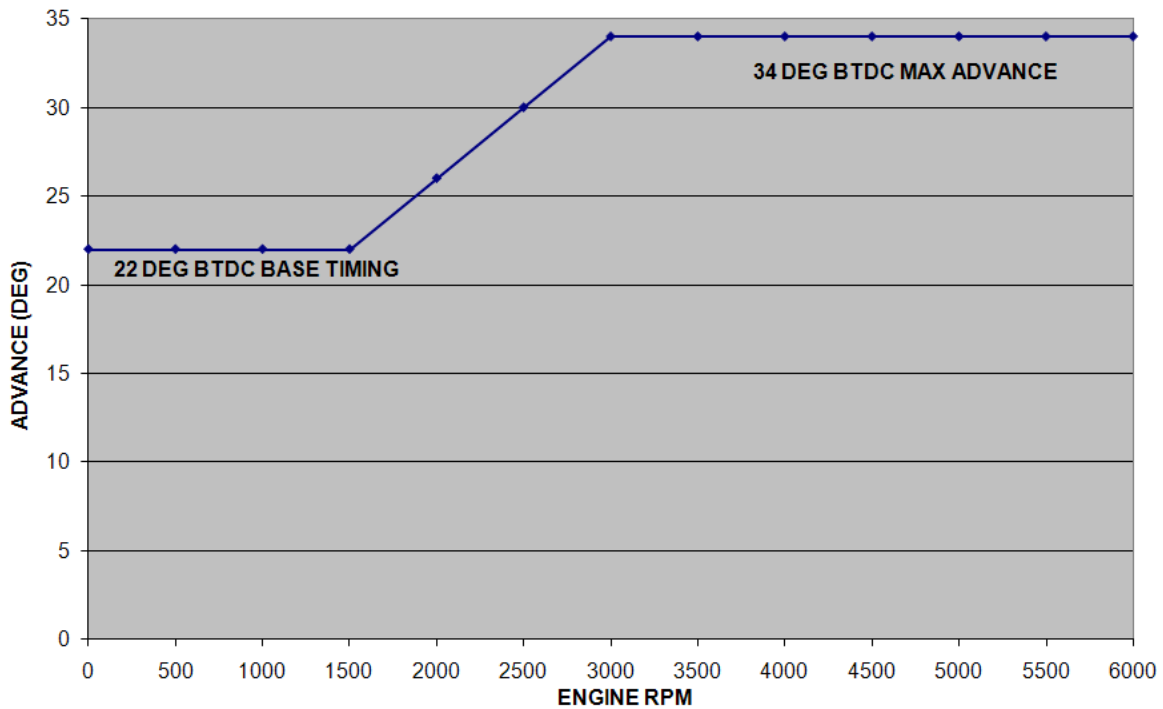

TEMPLATE FOR MERCURY MARINE ROTOR MODIFICATION

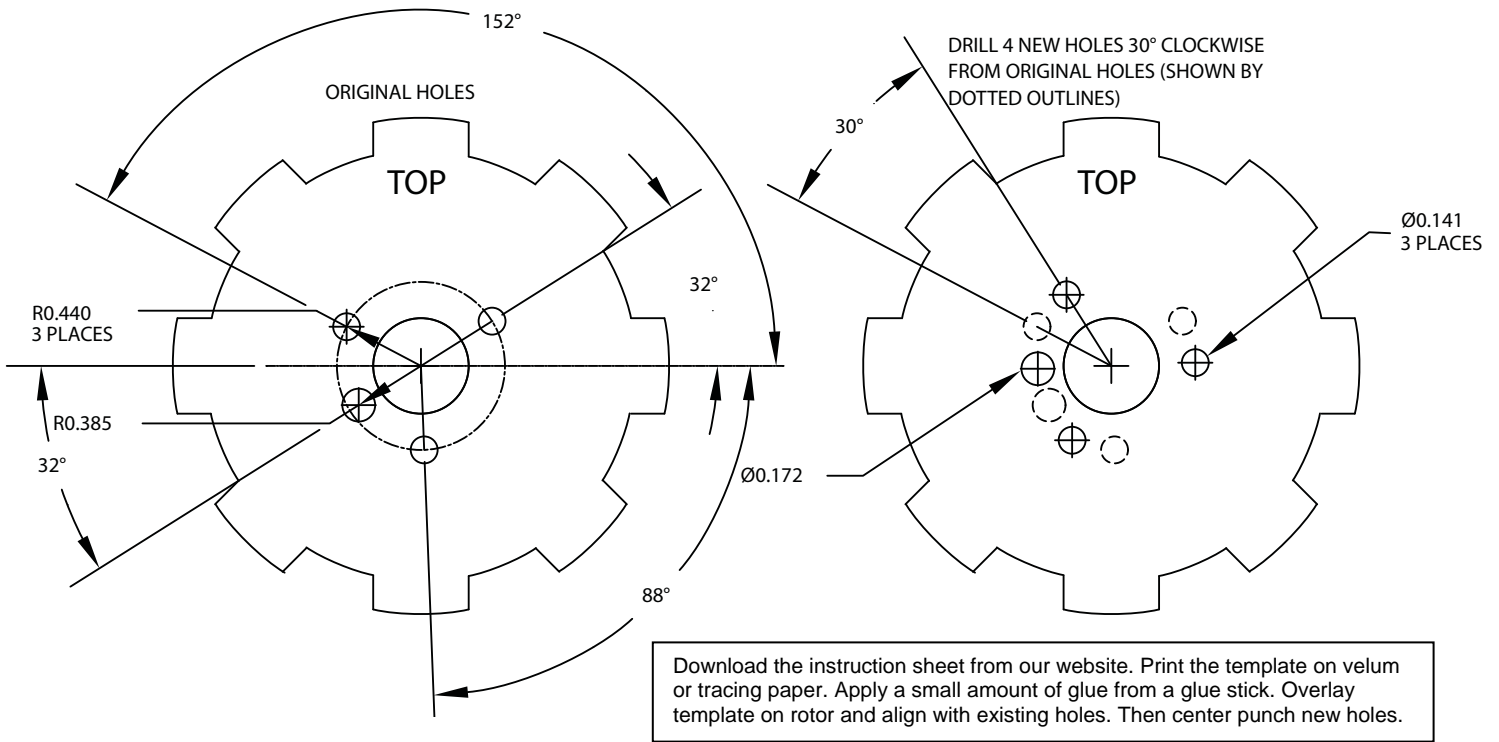

APPENDIX – RECOMMENDED PARTS AND SUPPLIERS

MAP SENSORS

To connect a Delphi MAP sensor for boost timing retard mode or for implementing a 3D timing table, you will have to fabricate a wiring harness with the appropriate mating connector or use our MAP sensor harness kit P/N 102006. Recommended Delphi MAP sensors, and equivalent aftermarket parts are listed in the table below. Note that Wells is stocked by Autozone (www.autozone.com) and SMP (Standard Motor Products) is stocked by RockAuto (www.rockauto.com).

Range	Delphi P/N	Aftermarket P/Ns
1 bar (normally aspirated engines)	12219927, 16254719, 16175339, 12247561	Wells SU105 SMP AS165
2 bar (0-15 psi boost)	16009886	Wells SU129 SMP AS4
3 bar (0-30 psi boost)	12223861	Wells SU504 SMP AS210

WIRE

Corrosion is the number one enemy of marine electrical systems. Do not use un-tinned copper wire. The unprotected copper in this inexpensive wire quickly oxidizes, especially when in contact with dissimilar metals on terminals. We recommend the use of high quality industrial grade wire with tinned copper strands and a high strand count.

18-20 AWG sizes can be used for all signal and low current applications. Carol UL grade 1007/1015 wire is available from Digi-Key.

P/N	Description
C2040X-100	20 AWG wire (100 foot spool)
C2064X-100	18 AWG wire (100 foot spool)
C2104X-100	16 AWG wire (100 foot spool)
C2105X-100	14 AWG wire (100 foot spool)

Note: replace X with color code B=Black, W=White, R=Red, G=Green, A=Orange, Y=Yellow, L=Blue, N=Brown, S=Gray, V=Violet

CRIMP TERMINALS

High quality crimp terminals and a proper crimping tool are required to make reliable electrical connections. Crimp terminals commonly sold in automotive and hardware stores have brittle vinyl insulation that easily cracks. For marine applications, we recommend Molex Perma-Seal nylon insulated crimp terminals with hot-melt adhesive lined sleeves. The following parts are available from Mouser.

P/N	Description
19164-0003	18-22 AWG #10 ring tongue terminal
19164-0004	18-22 AWG 1/4" ring tongue terminal
19164-0005	18-22 AWG 3/8" ring tongue terminal
19164-0026	14-16 AWG 1/4" ring tongue terminal
19164-0027	14-16 AWG 5/16" ring tongue terminal
19164-0066	10-12 AWG 1/4" ring tongue terminal
19164-0067	10-12 AWG 5/16" ring tongue terminal
19164-0017	18-22 AWG 1/4" female quick disconnect terminal
19164-0050	14-16 AWG 1/4" female quick disconnect terminal
19164-0013	18-22 AWG butt splice
19164-0044	14-16 AWG butt splice
19164-0056	10-12 AWG butt splice

RELAYS

The typical import brand 30-40 amp relays leave little safety margin. When used to switch heavy inductive solenoid loads, arcing can result in the contacts welding together – a potentially catastrophic failure mode. We recommend using Tyco/P&B automotive OE grade relays available from Newark Electronics and Digi-Key. Use the 40 amp version for most applications and the 70 amp version for heavy duty applications. We recommend that you use the relay sockets and crimp terminals listed along with the relays.

P/N	Description
1432791-1	40 amp VF4 series relay
VCF4-1001	Socket for VF4 series relay
60249-1	12-16 AWG terminal for VF4
VF7-41F11	70 amp VF7 series relay
VCF7-1000	Socket for VF7 series relay
42281-1	14-18 AWG terminal for VF4 coil connections (2 required)
280756-4	10-14 AWG terminal for VF7 contact connections (2 required)

FUSES AND FUSE TAPS

ATC series fuses and fuse holders commonly used for automotive applications are only available in 40 amp and lower ratings. For high current applications, we recommend the heavy duty 50 amp Littlefuse Maxi Fuse series available from Digi-Key.

P/N	Description
F1085	Maxi fuse block
F1038	50 amp Maxi fuse

SWITCHES

All switches used in marine performance applications should be sealed. Representative sealed toggle and rocker style switches available from Digi-Key are listed below.

P/N	Description
480-2191	Honeywell SPDT toggle switch
360-2278	NKK SPDT rocker switch

RELIABLE CONNECTIONS TO EXISTING SIGNALS

For some applications, you may have to tap into existing signal wires. We caution against using any of the so called "vampire clips" that make an insulation displacement connection. These have proven very unreliable in racing applications. They may even cause the original wire to fray and break. We suggest soldering any connections to existing signals. Use a stripping tool to cut through and push back about 1/4" of insulation at the spot on the original wire where you plan to make the connection. Wrap several turns of the new wire around, solder, insulate with self vulcanizing electrical tape, and use two cable ties to secure the splice as shown. Regular electrical tape will tend to unravel. Self vulcanizing electrical tape is available from Digi-Key as their P/N W213.

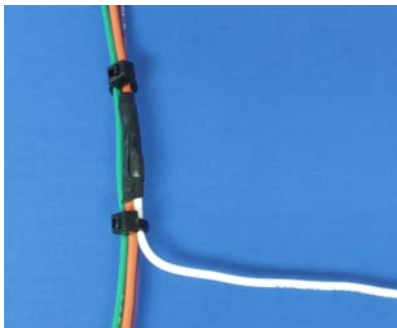

SUPPLIERS

Suppliers referenced in the Appendix are listed in the table below. Additional suppliers for connectors, electronic tools, mechanical hardware, and test equipment are listed on our website at www.daytona-sensors.com/tech_tools.htm.

Supplier	Phone	Website
Digi-Key	1-800-344-4539	www.digi-key.com
Mouser	1-800-346-6873	www.mouser.com
Newark	1-800-463-9275	www.newarkinone.com
State Wire & Terminal	1-800-922-6527	www.statewire.com