



CAUTION: CAREFULLY READ INSTRUCTIONS BEFORE PROCEEDING

OVERVIEW

This WEGO IIID kit is intended for easy hookup to a SuperFlow dyno that was previously equipped with Innovate LM-1 wide-band exhaust gas oxygen sensor interfaces. The kit includes a WEGO IIID dual channel wide-band exhaust gas oxygen sensor interface, two Bosch LSU 4.2 wide-band sensors, two custom length sensor extension cables, and power supply. The WEGO IIID is supplied with connectors that directly plug into the SuperFlow auxiliary input cable (P/N 1200A-2052-01).

MOUNTING AND CABLE ROUTING

The WEGO IIID unit can be mounted on the dyno control cabinet using screw hardware or Velcro material (not supplied). Choose a mounting location that will allow access to the calibration trimpots and status LEDs. The power supply should be located on the floor in a dry area. The WEGO IIID has three foot sensor cables. Before ordering, carefully measure the required length of the sensor extension cables, allowing several feet slack. Route the sensor extension cables away from sources of AC electrical noise and exhaust heat.

DYNO HOOKUP

Refer to Figure 1. Connect the sensor extension cables and Bosch sensors. Channel 1 is color coded with a yellow band. Connect the WEGO IIID to the power supply. Connect the power supply to 120 VAC power. Note that the power supply has a universal 100-240 VAC input. For overseas use, you will have to supply an appropriate power cord. The power supply

should be connected to a switched AC outlet. To avoid sensor damage from exhaust deposits, power must be turned on whenever the sensors are exposed to exhaust gases.

Connect the WEGO IIID output to the Superflow auxiliary input cable. Mating connectors are installed on the WEGO IIID, with channel 1 identified by a yellow band at the connector end.

SUPERFLOW SYSTEM CONFIGURATION

The WEGO IIID output is scaled differently than the Innovate LM-1, thus the dyno configuration file must be edited.

1. In the WinDyn program, click on **Design** and then **System Configuration**. A DOS editor window will open.
2. **GET** the MCDYNO.CFD file.
3. **EDIT** channels 103 and 104 as follows (hit Escape key to edit):
$$103 = (C5*2)+10$$
$$104 = (C4*2)+10$$
4. **KEEP** the file. This will overwrite the existing MCDYNO.CFD file.
5. **QUIT** the editor.
6. Reinstall the MCDYNO.TGP test group via the **F2** function key. The WinDyn program will now show correctly scaled data from the attached WEGO IIID.

Figure 1 – WEGO IIID Hookup to SuperFlow Dyno

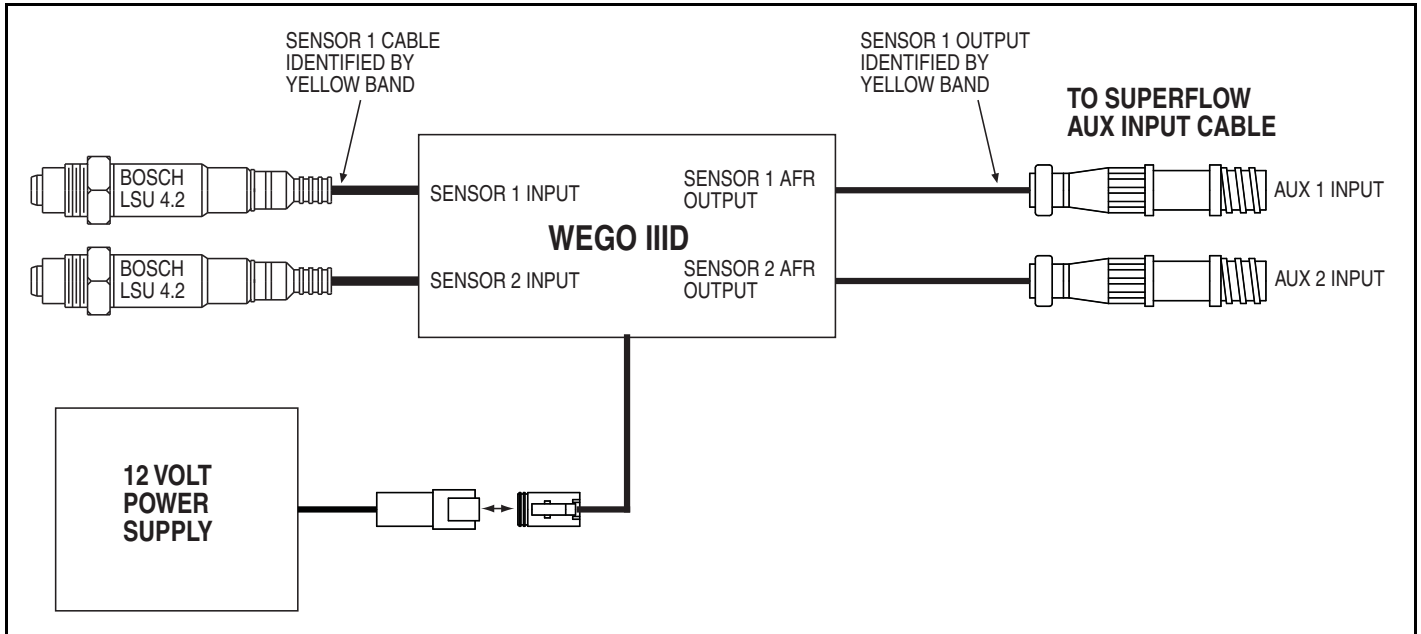

SENSOR LIFE AND CALIBRATION

When used in a racing application with leaded gasoline, sensor life will probably be less than 10 hours. Free air calibration should be performed on a regular basis, such as before the start of every test session. If free air calibration fails, the sensor should be replaced. Free air calibration must be performed in an environment free of hydrocarbon vapors.

The WEGO IIID uses standard Bosch LSU 4.2 sensors used on a VW production application (Bosch P/N 0 258 007 057/058 or VW P/N 021 906 262B). The proprietary VW connector is replaced with a smaller Deutsch DT-04-6P available from Ladd Industries. We offer replacement sensors with the Deutsch connector installed. If you plan to terminate your own sensors, use the following color chart:

Terminal	Wire Color
1	Red
2	Black
3	Yellow
4	White
5	Gray
6	Seal