



**CAUTION: CAREFULLY READ INSTRUCTIONS BEFORE PROCEEDING**

## OVERVIEW

The WEGO IV dual channel unit (WEGO 4D) is a complete air/fuel ratio (AFR) metering system with built-in data logging. The system is a versatile tuning aid and diagnostic tool for all carbureted and fuel injected gasoline powered engines. The WEGO IV unit displays AFR for two channels and can log over 3 hours data including sensor 1 and sensor 2 AFR values, engine RPM, and a spare 0-5V analog input for sensors such as throttle position or manifold pressure. The ultra-bright daylight readable blue LED display features automatic dimming under low light conditions. The compact size and wide supply voltage range also allow operation from small rechargeable batteries in a broad range of applications.

The system uses low cost Bosch LSU 4.2 5-wire wide-band oxygen sensors. By utilizing miniature surface mount electronics technology, digital signal processing techniques, and a switching power supply for the sensor heater, the WEGO IV provides the same level of accuracy as lab systems costing thousands of dollars.

WEGO IV units also have 0-5 volt analog AFR outputs that are compatible with most data acquisition systems.

## REPLACEMENT SENSORS AND ACCESSORIES

The WEGO IV uses standard Bosch LSU 4.2 sensors used on a VW production application (Bosch P/N 0 258 007 057/058 or VW P/N 021 906 262B). The proprietary VW connector is replaced with a smaller Deutsch DT-04-6P. We offer replacement sensors with the Deutsch connector installed.

If you are testing multiple engines, we also offer additional 18 x 1.5 mm weld nuts for sensor mounting and 18 x 1.5mm hex socket plugs that screw into the weld nuts and allow removing sensors after tuning.

Some engines using CD (capacitive discharge) ignitions may require a special tach adapter for engine RPM data logging. Please call our tech support at 386-322-7390 for details.

## INSTALLATION

1. Turn off the ignition switch before proceeding.
2. Select a convenient mounting location for the Bosch sensors. In general, the sensors should be mounted as close to the exhaust valves or exhaust manifold as practical. When choosing a mounting location, allow several inches clearance for the sensor wire harness. The wire harness must exit straight out from the sensor. Do not loop the harness back onto the sensor body. The sensor responds to oxygen pressure. Excessive backpressure will cause a reading error. For turbocharged applications, you must mount the sensors downstream of the turbo.
3. For temporary use during dyno tuning, you can mount the Bosch wide-band sensors in place of the original equipment rear oxygen sensors (after the catalytic converter). You can also use sniffers in the tailpipe. For permanent mounting, 18 x 1.5 mm weld nuts must be welded onto the exhaust pipe. After welding, run an 18 x 1.5 mm tap through the threads. Failure to clean the threads may result in sensor damage. Note that most automotive muffler shops are familiar with oxygen sensor weld nut installation on custom pipes. Do not install the sensors until after the free air calibration procedure described in the following section. Always use an anti-seize lubricant such as Permatex 133A on the sensor threads.
4. Install the WEGO IV unit where the display will be visible during testing. The unit is not sealed and must be mounted in a dry location away from sources of heat. We recommend underdash mounting or use in a dyno lab environment. The unit is not intended for underhood mounting. The unit can be secured by means of Velcro tape strips. Use nylon tie wraps to secure the wire harness near the unit.
5. **Working with clamping terminal blocks.** All connections to the WEGO IV terminal block must be clearly identified either by means of distinct wire colors (such as shown in Figure 1) or wire labels. If you use different wire colors, mark up Figure 1 for future reference. All connections can be made with 18-20 AWG wire. Wire should be stripped back

3/16-1/4 inch. No bare wire should be visible outside the terminal block. Use a miniature Phillips or flat screwdriver to tighten the screws.

6. Connect the Bosch sensors to the 6 pin mating connectors on the supplied extension cables. You can shorten the extension cables if required. Longer 12 foot extension cables (P/N WEGO-CBL-12) are also available.
7. Refer to Figure 1. Connect the WEGO IV ground wires to a good frame ground location. Use 18 AWG wire for the power ground connection. If you

are using a data acquisition system, connect the ground wires to the same point that the data acquisition system is grounded. Keep the ground connections as short as possible. Try to use an existing wire harness ground location. **Do not ground the WEGO IV to the battery minus terminal or to the engine.**

8. Connect the WEGO IV +12V power to switched +12 volt power. You can usually find switched +12V power at an accessory fuse on the fuse block. You can use the supplied fuse tap and 3/16" female crimp terminal for this purpose.

Figure 1 - WEGO IV Dual Channel Hookup

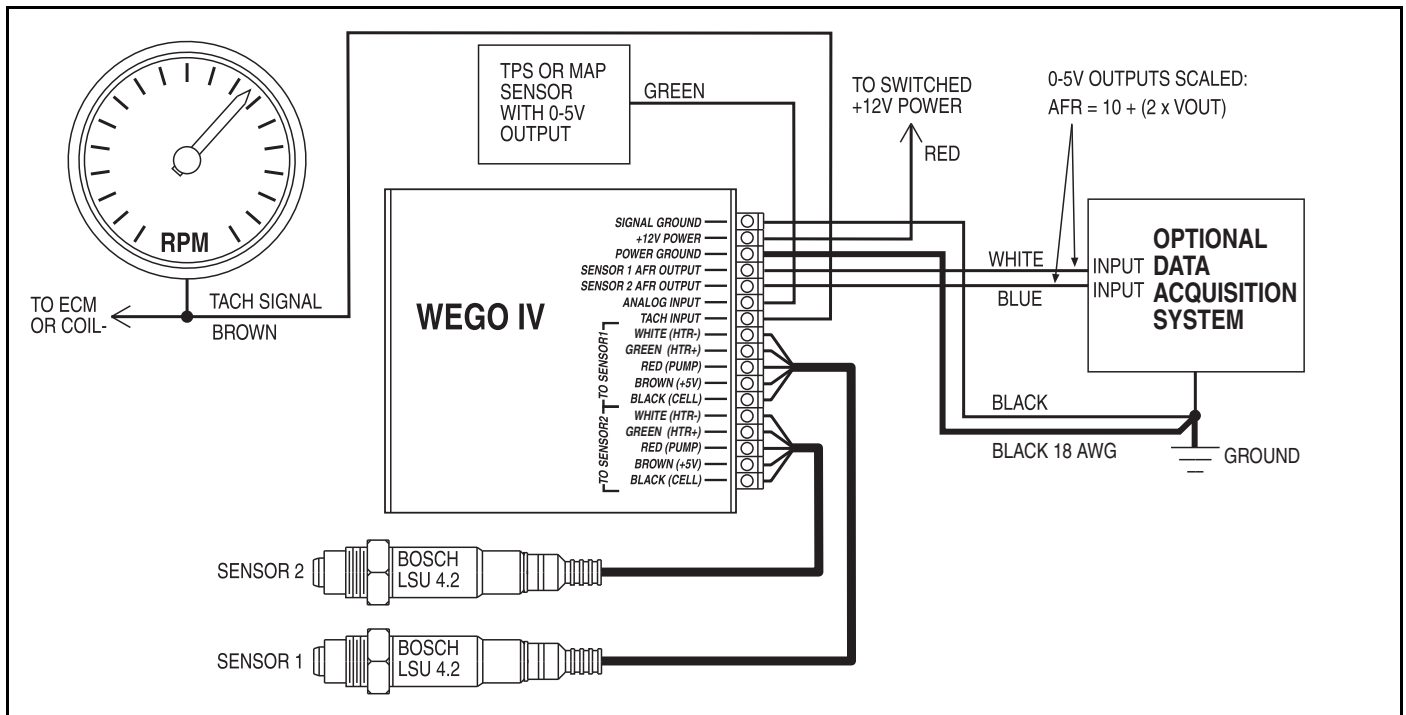

9. Optional signal hookups, including engine RPM and analog signal data logging, are explained in sections 10-12.
10. For engine RPM data logging, connect the WEGO IV tach input to one of the following:
  - a. **Tach signal (preferred for best noise immunity).** The unit is compatible with industry standard 12 volt square wave tach signals such as what would be used to drive an Autometer or similar aftermarket tach. Most aftermarket CD (capacitive discharge) ignitions including the MSD-6 and Crane HI-6 series have a tach output that you can connect to the WEGO IV.

1999-2003 Harley-Davidson® motorcycles with carbureted Twin Cam 88® engines have a tach output on pin 12 of the black ignition module connector. Most 2001 and later Harley-Davidson® motorcycles with 36 pin Delphi® fuel injection ECM have a tach output on pin 3 of the ECM connector.

- b. **Coil- terminal.** The unit is compatible with the signal on the Coil- terminal of most inductive discharge type ignitions. This includes most OE (original equipment) automotive ignitions and all Harley-Davidson® ignitions. For automotive distributorless or Harley-Davidson® single fire systems with multiple coils or coil

packs, you can use any one of the Coil-signals.

- c. **Motorcycle and small engine CD (capacitive discharge) ignitions.** Many Japanese motorcycles and small engines use CD ignitions. Any engines with flywheel triggered systems fall into this category. These applications will require a special tach adapter P/N WEGO-TACH-ADAPT.

**If you have a Japanese motorcycle, download the WEGO Tach Adapter instructions from our website at [www.daytona-sensors.com](http://www.daytona-sensors.com). Tips are provided for identifying the type of ignition system in use.**

The WEGO IV Dual Channel Log software is used to set the correct scaling for engine RPM in terms of pulses per revolution. The unit can easily be set up for operation with 1-12 cylinder engines. Refer to the software instructions for details.

**WARNING: Directly connecting the WEGO IV tach input to the coil of a CD type ignition will damage the unit and void the warranty.**

11. For analog signal data logging, connect the WEGO IV analog input to one of the following:
  - a. **Throttle position sensor.** Most engine controls use a TPS (throttle position sensor) with a 0-5 volt signal range. Refer to your service manual for details.
  - b. **Manifold pressure sensor.** Most engine controls use a MAP (manifold pressure sensor) with 0-5 volt signal range. Refer to your service manual for details.
  - c. **Other 0-5V analog signals.** The WEGO IV can log any 0-5V signal. For other sensors, use a scope meter to check the signal before connecting it to the WEGO IV.

The WEGO software is used to set the units and scaling for the analog input. Refer to the WEGO software instructions for details.

**WARNING: Connecting the WEGO IV analog input to a high voltage (in excess of 12 volts) will damage the unit and void the warranty.**

12. Optional AFR outputs. You can connect the WEGO IV AFR outputs to 0-5V analog inputs on a data acquisition system. Refer to Figure 1 for scaling.

## OPERATION

For more information about wide-band oxygen sensors including the Bosch LSU 4.2, we suggest that you visit the Tech FAQ on our website at [www.daytona-sensors.com](http://www.daytona-sensors.com).

The WEGO IV display shows AFR and status data. The unit includes internal diagnostics for abnormal battery voltage (less than 11 volts or greater than 16.5 volts), sensor open circuit, sensor short circuit conditions, and excessive temperature. When power is turned on, the display will show "CL" (cold) until the attached sensor has reached normal operating temperature. The unit will then display an AFR value, "FA" (free air), "PC" (during PC communications), or diagnostic codes: "SO" (sensor open circuit), "SS" (sensor short circuit), "Lb" (low battery voltage), "Hb" (high battery voltage), or "OT" (over-temperature warning).

Figure 2 - WEGO IV Dual Channel Unit



After installation, the WEGO IV system requires free air calibration. This should be done with the sensors dangling in free air. The environment must be free of hydrocarbon vapors. We suggest that you perform the free air calibration outdoors. Turn the free air calibration trimpots (located on the bottom of the WEGO IV unit) full counterclockwise. Turn on power and wait for 60 seconds so the system can fully stabilize. Then slowly turn each free air calibration trimpot clockwise until the corresponding display indicates "FA". Try to set each trimpot at the point where the display just starts to indicate "FA". The free air calibration procedure should be performed at reasonable intervals (every 250-500 hours) or

whenever a sensor is replaced. If you cannot get the display to indicate "FA" when the trimpot is turned full clockwise (sensor in free air), you either have a damaged sensor or very high hydrocarbon levels in your environment.

The WEGO IV will start logging data once both sensors have reached normal operating temperature and the unit displays an AFR value or "FA". The unit will not log data when "CL" or "PC" is displayed. The unit stops logging data while a diagnostic code is set (however the code is logged). The interval between samples can be set from 0.1-1.0 seconds using the og software. The unit stores the last 12,000 samples. The software also displays any logged diagnostic codes. Refer to the software instructions for details.

The "OT" diagnostic code indicates that the WEGO IV unit (not the sensor) is too hot. This may occur if the unit is operated for an extended period of time at ambient temperatures above 150° F.

## EXHAUST CONSIDERATIONS

The WEGO IV system may give inaccurate results in certain situations:

**Excessive exhaust back pressure.** Wide-band sensors are affected by back pressure. Excessive back pressure causes exaggerated AFR indications under rich and lean conditions, but has little effect at 14.7 AFR (stoichiometric). The WEGO IV is intended to be used with a free flowing performance exhaust. Overly restrictive stock mufflers may cause excessive back pressure under wide open throttle. When used with a turbo system, the sensors must be mounted downstream of the turbo.

**Exhaust reversion.** Reversion is the term for a negative pressure wave that can suck ambient air back into the exhaust and cause an erroneous lean AFR indication. Exhausts without mufflers, such as open headers or "drag pipes" on motorcycles, usually suffer from reversion effects and may not be suitable for use with the WEGO IV. Reversion effects will also occur with certain exhausts used on "bagger" style motorcycles, where two pipes split off near the rear cylinder. Reversion effects will be most noticeable at idle, part throttle low RPM cruise, and decel.

**Excessive scavenging.** Turbo systems or tuned exhausts in combination with a high overlap camshaft profile can force unburned air and fuel mixture through the cylinder into the exhaust and cause an erroneous rich AFR indication.

**Misfiring.** If the AFR is so rich that the engine misfires, high levels of oxygen will remain in the exhaust gas and result in an erroneous lean indication.

## APPLICATIONS

WEGO IV units are useful in a wide range of engine tuning and testing applications. After free air calibration, accuracy is  $\pm 0.1$  AFR over the 10.3-19.5 AFR range. The 0-5 volt analog outputs are scaled:

$$\text{AFR} = 10 + (2 \times \text{Vout}) \quad \text{or}$$

$$\text{Vout} = (\text{AFR} - 10)/2$$

For example, an output of 2.5 volts corresponds to 15.0 AFR. This scaling is convenient for many data acquisition systems. When power is first turned on and the sensors are not yet at their normal operating temperature, the analog outputs are held at less than 0.20 volts. During free air calibration and while the unit displays "FA", the analog outputs will be near 5.0 volts.

WEGO IV units also feature low power consumption (about 2 amp) and a wide operating voltage range (11-16 volts). You can power the WEGO IV for over one hour from a 12 volt gel cell type rechargeable battery, such as the type used for backup power in alarm systems.

## ENGINE TUNING GUIDELINES

Higher AFR values correspond to a leaner (less fuel) condition. The practical operating range for most engines using gasoline fuel is from approximately 11.5 to 14.7 AFR. Combustion of a stoichiometric mixture (exactly enough air to burn all the fuel) results in 14.7 AFR indication. Automotive engines with catalytic converters operate near 14.7 AFR during cruise and idle. Race engines usually require a richer mixture to limit cylinder head temperature and prevent detonation. The table below lists reasonable AFR values for race engines without emission controls.

Operating Mode	Recommended AFR
Cold Start (first 30 sec)	11.5-12.5
Idle	12.8-13.5
Part Throttle Cruise	13.0-14.0
Wide Open Throttle (normally aspirated)	12.5-12.8 (values down to 11.5 may be used to reduce detonation)
Wide Open Throttle (turbo/supercharged)	10.8-11.8

## EXHAUST SNIFFERS

WEGO IV units can be used with easily fabricated exhaust sniffers that allow temporary installation on most automobiles and motorcycles for tuning and diagnostic purposes, including vehicles with catalytic converters. The exhaust sniffers are constructed from materials that are readily available at any hardware store. For more details, download the Automotive Exhaust Sniffer Tech Note and Motorcycle Exhaust Sniffer Tech Note from our website at [www.daytona-sensors.com](http://www.daytona-sensors.com).

## TROUBLESHOOTING FLOWCHART

Follow the troubleshooting flowchart shown below for each channel. Experience has shown that most units returned for warranty are OK and another problem, such as user error, degraded sensors, or bad power connections is later identified.

### Troubleshooting Flowchart

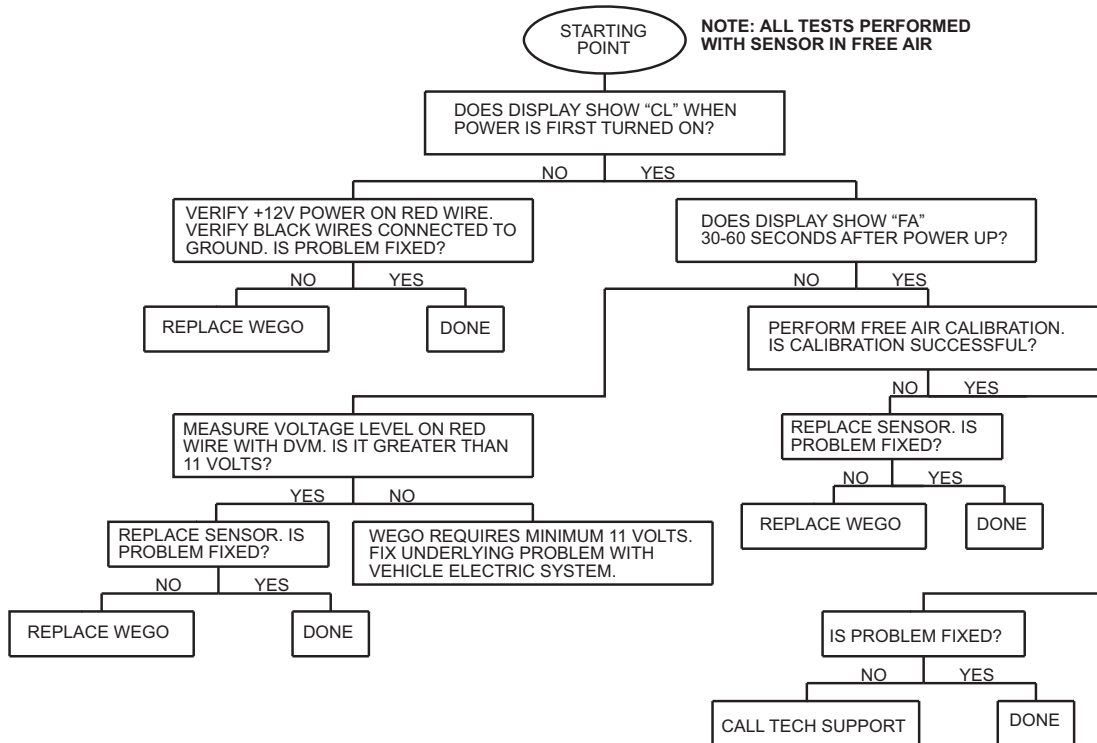

**CAUTION: WEGO IV units are not sealed. These units are intended for dash mounting or use in dry environments. There is no warranty on units with moisture damage.**

**CAUTION: Racing gasoline containing lead will quickly degrade the sensors. Under these conditions, expected sensor life is less than 10 hours. There is no warranty on sensors.**